



## M B MASTER-BILT<sup>®</sup>

MASTER-CHILL<sup>™</sup>

### MBC SERIES

#### Undercounter Blast Chillers/Freezers

**EXCLUSIVE  
F.I.C.  
TECHNOLOGY**

SEE PAGE 2

- MBCF44/24-4
- MBCF44/24-4B

## FEATURES

### CONSTRUCTION

- Stainless steel interior and exterior
- Satin Scotchbrite finish on door, side panels, control panel and top
- Polished interior including diamond-polished inner floor for improved hygiene
- CFC-free polyurethane foamed-in-place insulation
- Wall thickness: 2.36"
- One-piece construction with rounded internal corners
- Hinged fan cover for easy cleaning access to the evaporator and fan
- Drain outlet for easy interior cleaning
- Removable stainless steel half racks and container support guides
- Plastic defrost drip tray on outer base
- Stainless steel legs with plastic heat-resistant pads, height adjustable from 4.5" to 6.5"
- Standard product core probe with L-shaped handle for easy extraction

### DOORS

- Self-closing door with full-height outer stainless steel handle
- Removable magnetic gasket
- Door frame heating element

### CONTROL PANEL

- LCD display showing 2 rows with 16 characters on each row
- Blast chilling with variable cycle progression
- 20 pre-set blast-chilling cycles
- Variable speed drives on evaporator fans for accurate temperature control and energy efficiency
- HACCP history
- Five-language library
- Displays interior temperature, product temperature, ventilation speed
- Automatic setting of refrigerating phase at end of cycle

### REFRIGERATION

- Cooling unit at evaporation temperature -13°F and condensation temperature 128°F rated at 813 watt with hermetic compressor
- Refrigerant: R404A
- Production per cycle: 44 lbs. of product from +194°F to +37.4°F in 90 minutes and 26 lbs. from +194°F to 0°F in 240 minutes
- Pre-set inner cell temperature during chilling cycle: +32, +23, -13°F

- Pre-set inner temperature during freezing cycle: -13°F
- Evaporation temperature control with thermostat valve
- Internal operation: ventilated cell, ventilation can be reduced for particular delicate foods
- Copper/aluminum corrosion-proofed evaporator
- Manual defrost

### WARRANTY

- Standard limited four year extended compressor and one year limited parts and labor

## OPTIONS

- Additional wire shelves
- Additional support guides



# MASTER-CHILL™ MBC SERIES

## UNDERCOUNTER BLAST CHILLERS/FREEZERS

### EXCLUSIVE F.I.C. TECHNOLOGY

Master-Chill MBC models feature the newest patented technology in blast chillers/freezers with the Food Identification Controller (F.I.C.). The F.I.C. automatically adjusts blast chilling cycles with its single multi-sensor probe. The F.I.C. monitors temperatures in the core, beneath and on the surface, preventing surface freezing and degradation as well as preserving nutritional values of the food.



### TECHNICAL SPECIFICATIONS

MODEL	DIMENSIONS (in.)			DIMENSIONS (mm)			VOLTS/ HZ/PH	AMPS	UNIT H.P.	NO. OF SHELVES	STANDARD SHELF DIMENSIONS (in.)	NO. OF SHELF SUPPORT RACKS	SHIP CU. FT.	SHIP WT. LB/KG
	L	D	H*	L	D	H*								
MBCF44/24-4	29 <sup>5</sup> / <sub>16</sub>	27 <sup>9</sup> / <sub>16</sub>	33 <sup>1</sup> / <sub>2</sub>	745	700	851	220/60/1	5.5	1	3	15 <sup>3</sup> / <sub>4</sub> x 23 <sup>11</sup> / <sub>16</sub>	4 pairs	24.0	276/125
MBCF44/24-4B	29 <sup>5</sup> / <sub>16</sub>	27 <sup>9</sup> / <sub>16</sub>	39 <sup>3</sup> / <sub>8</sub>	745	700	1000	220/60/1	5.5	1	3	15 <sup>3</sup> / <sub>4</sub> x 23 <sup>11</sup> / <sub>16</sub>	4 pairs	27.5	276/125

\*Height includes legs.

### PAN CAPACITIES

MODEL	1/1 GASTRONORM (530 x 325 x 40mm)	2/1 GASTRONORM (530 x 650 x 40mm)	12" X 20" X 2.5"	12" X 20" X 1.5"	18" X 26" X 2.5"	18" X 26" X 1.5"
MBCF44/24-4	5	NA	4	5	NA	NA
MBCF44/24-4B	5	NA	4	5	NA	NA

**MBCF44/24-4**

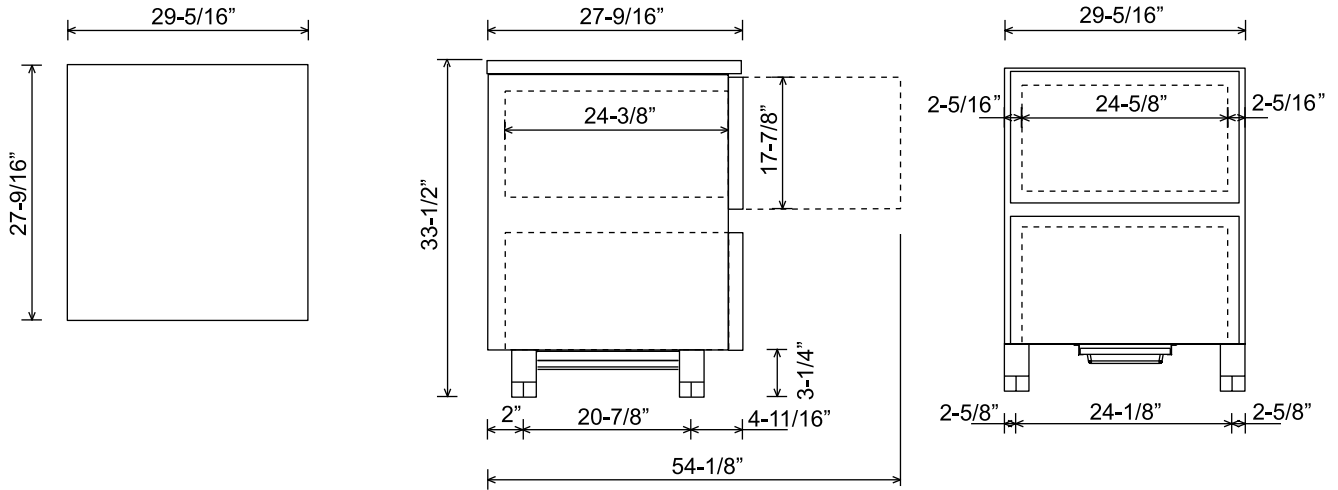

**MBCF44/24-4B**

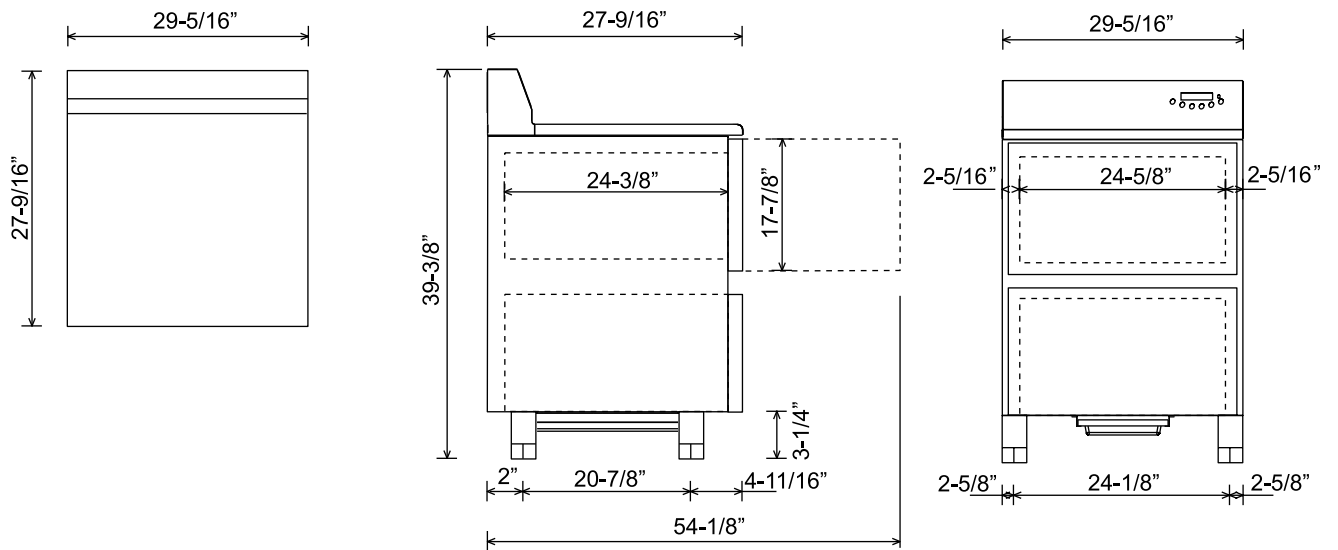

**PLAN VIEW**

**SIDE VIEW**

**ELEVATION VIEW**



**MASTER-CHILL™ MBC SERIES**  
**UNDERCOUNTER BLAST CHILLERS/FREEZERS**

**LISTINGS**



**HOOKUP**

Both models are hardwired.

**BID SPECIFICATIONS**

Item no. MBC-\_\_\_\_\_  
 Provide\_\_\_\_\_( )  
 Undercounter Blast Chiller/  
 Freezer(s), Master-Bilt model no.  
 MBC-\_\_\_\_\_.

Blast chiller/freezer will be constructed of stainless steel interior and exterior with diamond polished inner floor and rounded internal corners.

Blast chiller/freezer will feature patented Food Identification Controller with single multi-sensor probe.

Other features will include stainless steel legs adjustable from 4.5 to 6.5 inches, a hinged fan cover for easy cleaning access and a corrosion-proofed evaporator coil.

The refrigeration system is to be self-contained and use R-404A refrigerant.

Blast chiller/freezer to have standard limited four year extended compressor warranty and one year limited parts and labor warranty.

Blast chiller/freezer will be UL and NSF listed.

**NOTE: Cabinet designed for optimum performance in air-conditioned area at 75°F ambient and 55% relative humidity. All specifications subject to change without notice.**



908 Highway 15 North • New Albany, MS 38652  
 PHONE: 800-647-1284 or 662-534-9061 • FAX: 800-232-3966 or 662-534-6049 • [www.master-bilt.com](http://www.master-bilt.com)

