

# **MIB** MASTER-BILT®

*Refrigeration Solutions*

TAC-27

TAC-48

TAC-74

## **Installation & Operations Manual**

**Master-Bilt Products**  
908 Highway 15 North  
New Albany, MS 38652  
Phone: (800) 684-8988

PN 217-90000  
10/16/03



## TABLE OF CONTENTS

INTRODUCTION.....	4
4	
STORE CONDITIONS.....	4
WARNING LABELS AND SAFETY INSTRUCTIONS.....	5
PRE-INSTALLATION INSTRUCTIONS.....	6
Inspection for Shipping Damage.....	6
INSTALLATION INSTRUCTIONS.....	7
General Instructions.....	7
Location.....	7
Dimensional Data.....	7
STARTING PROCEDURE.....	8
FINAL CHECK LIST.....	8
SERVICE INSTRUCTIONS.....	9
MASTER-BILT PART NUMBERS.....	10
SALE AND DISPOSAL.....	11
WIRING DIAGRAMS TAC27.....	12
WIRING DIAGRAMS TAC27R.....	13
WIRING DIAGRAMS TAC48.....	14
WIRING DIAGRAMS TAC48R.....	15
WIRING DIAGRAMS TAC74.....	16
WIRING DIAGRAMS TAC74R.....	17
WIRING DIAGRAMS TAF27.....	18
WIRING DIAGRAMS TAF48/TAF74.....	19
WIRING DIAGRAMS TAF-ALL REMOTE AND QUICK CONNECT.....	20

## INTRODUCTION

Thank you for purchasing a Master-Bilt cabinet. This manual contains important instructions for installing, using and servicing a Master-Bilt **TAF/TAC** case. A parts list is included in with this manual. Read all these documents carefully before installing or servicing your equipment.

## STORE CONDITIONS

The Master-Bilt **TAF/TAC** cases are designed to operate in the controlled environment of an air conditioned store. The store temperature should be at or below 75°F and a relative humidity of 55% or less. At higher temperature or humidity conditions, the performance of these cases may be affected and the capacity diminished. It is not uncommon in a newly constructed store for the temperature and humidity to be above design conditions. These excessive conditions may produce sweating in the case until the store is operational and the ambient environment is more desirable.

The Master-Bilt **TAF/TAC** should not be positioned where it is directly exposed to rays of sun or near a direct source of radiant heat or air flow. This will adversely affect the case and will result in poor performance.

If this case is to be located against a wall there should be at least 4" space between the wall and the back of the case. This space will allow for the circulation of air behind the case which will prevent condensation on the exterior surfaces.



**Read this manual before installing your cabinet. Keep the manual and refer to it before doing any service on the equipment. Failure to do so could result in personal injury or damage to the cabinet.**



**Improper or faulty hook-up of electrical components of the refrigeration units can result in severe injury or death.**

**All electrical wiring hook-ups must be done in accordance with all applicable local, regional or national standards.**



**Installation and service of the refrigeration and electrical components of the cabinet must be performed by a refrigeration mechanic and/or a licensed electrician.**

The portions of this manual covering refrigeration and electrical components contain technical instructions intended only for persons qualified to perform refrigeration and electrical work. This manual cannot cover every installation, use or service situation. If you need additional information, call or write us:

Customer Service Department  
Master-Bilt Products  
Highway 15 North  
New Albany, MS 38652  
Phone (800) 684-8988  
Fax (800) 684-8988

## WARNING LABELS AND SAFETY INSTRUCTIONS



This symbol is the safety-alert symbol. When you see this symbol on your cabinet or in this manual, be alert to the potential for personal injury or damage to your equipment.

Be sure you understand all safety messages and always follow recommended precautions and safe operating practices.



### NOTICE TO EMPLOYERS

**You must make sure that everyone who installs, uses or services your cabinet is thoroughly familiar with all safety information and procedures.**

Important safety information is presented in this section and throughout this section and throughout the manual. The following signal words are used in the warnings and safety messages:

**DANGER:** Severe injury or death will occur if you ignore the message.

**WARNING:** Severe injury or death can occur if you ignore the message.

**CAUTION:** Minor injury or damage to your cabinet can occur if you ignore the message.

**NOTICE:** This is important installation, operation or service information. If you ignore the message, you may damage your cabinet.

**The warning and safety labels shown throughout this manual are placed on your Master-Bilt Products cabinet at the factory. Follow all warning label instructions. If any warning or safety labels become lost or damaged, call your customer service department at (800) 684-8988 for replacements.**

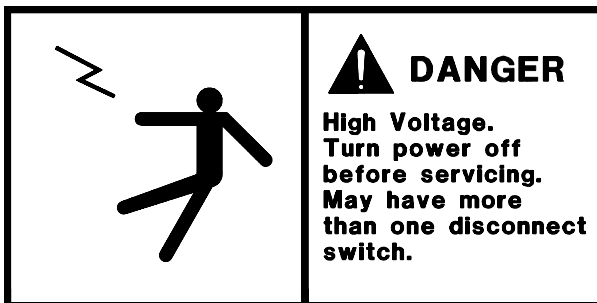

*This label is located on top of the electrical control label and on the wiring channel.*

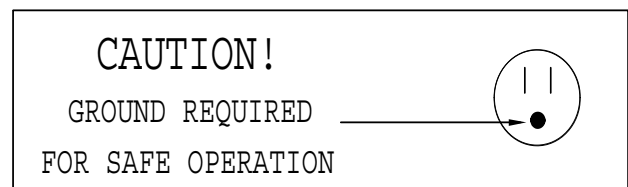

*This label is attached to the cabinet power cord on models with a power cord.*

## PRE-INSTALLATION INSTRUCTIONS

### INSPECTION FOR SHIPPING DAMAGE

You are responsible for filing all freight claims with the delivering truck line. Inspect all cartons and crates for damage as soon as they arrive. If damage is noted to shipping crates or cartons or if a shortage is found, note this on the bill of lading (all copies) prior to signing.

If damage is discovered when the cabinet is uncrated, immediately call the delivering truck line and follow up the call with a written report indicating concealed damage to your shipment. Ask for an immediate inspection of your concealed damage item. Crating material must be retained to show the inspector from the truck line.

## INSTALLATION INSTRUCTIONS

### GENERAL INSTRUCTIONS

1. Be sure the equipment is properly installed by competent service people.
2. Keep the equipment clean and sanitary so it will meet your local sanitation codes.
3. Rotate your stock so that older stock does not accumulate. This is especially important for ice cream. A "First-In, First-Out" rotation practice will keep the products in good salable condition.
4. Do not place product in the case when it is soft or partially thawed. Also, product should not be put in the case for at least 6 hours after it is started.
5. Stock cases as quickly as possible, exposing only small quantities to store temperatures for short periods of time.
6. When replacing burned out fluorescent tubes, be sure that the electrical power to the lighting circuit is turned off.

### MECHANICAL

Remove front grille and check refrigeration lines to see that they are free (not touching each other or compressor). Spin condenser fan blade to see that it is free.

Check that all service valves (2) are open. Cut compressor hold-down strap and remove. The springs are secured for shipping by either tightening bolts or shipping strap. Remove the strap or loosen the hold-down bolts so that the compressor floats freely. Check all refrigeration lines and electrical conduit for rubbing or chaffing, paying particular attention to area where lines enter the cabinet.

Remove cabinet from crate base and slide into location. Cabinet must be level from side to side and front to back for correct draining of coil pan and for self-closing doors to operate correctly. Allow minimum of 4" between back of cabinet and wall and between top of cabinet and ceiling for proper condensing unit air circulation.

To comply with Sanitation requirements the cabinet must be mounted on legs (6" high min.) or casters or the base must be sealed to the floor with an N.S.F. listed silicone sealant.

To comply with UL requirements the cabinet must have a minimum clearance of 4" at the top, 6" at the rear and 0" at each side.

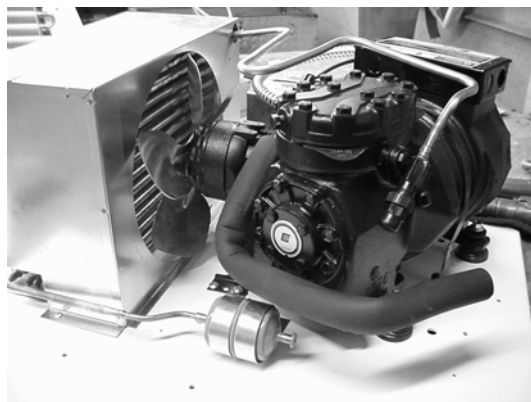

## NOTICE TO STORE OWNERS / MANAGERS

Moisture or liquid around or under the cabinet is a potential slip/fall hazard for persons walking by or working in the general area of the cabinet. Any cabinet malfunction or housekeeping problem that creates a slip/fall hazard around or under the cabinet should be corrected immediately.

If moisture or liquid is observed around or under a Master-Bilt cabinet, an immediated investigation should be made by qualified personnel to determine the source of the moisture or liquid. The investigation should determine if the cabinet is malfunctioning or if there is a drain pipe leaking.

## ELECTRICAL



### WARNING

Before servicing electrical components in the case or the doors or door frames make sure all power to case is off. Always use a qualified technician.

## INSTALLATION INSTRUCTIONS

To comply with N.S.F. requirements, this cabinet must be mounted on casters, legs (6" high min.) or the base must be sealed to the floor. The casters provided with this case screw into the holes from which the shipping bolts were removed.

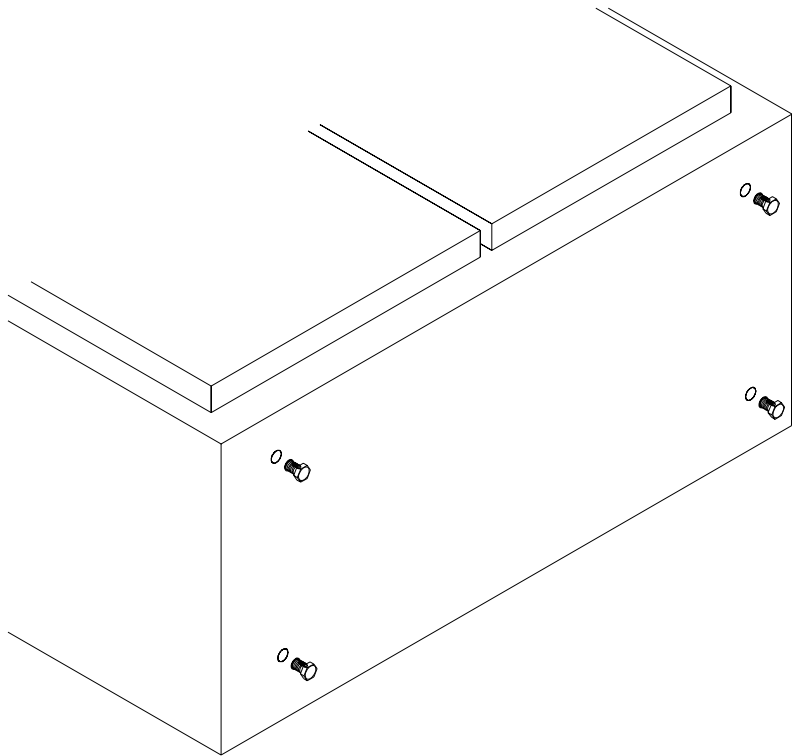

## CONDENSATE PAN INSTALLATION FOR TOP MOUNT CABINETS ONLY

1. Before moving cabinet into place, remove the condensate pan from the top unit compartment.
2. Using the two screws supplied with the pan, attach the pan to the back of the cabinet at the two holes near the bottom of the plastic drain line. Be sure pan is NOT located directly under cabinet. When the pan is attached, feed drain line into the open hole in screen and clamp the heater conduit to the back of the cabinet. Due to this condensate pan, this case must be a minimum of 6" from the wall.
3. If cabinet must be located next to wall on legs, the pan can be located under the cabinet. When this is done, steam will accumulate on the bottom of the cabinet if there is not adequate ventilation, and rusting of the bottom of the cabinet will occur.

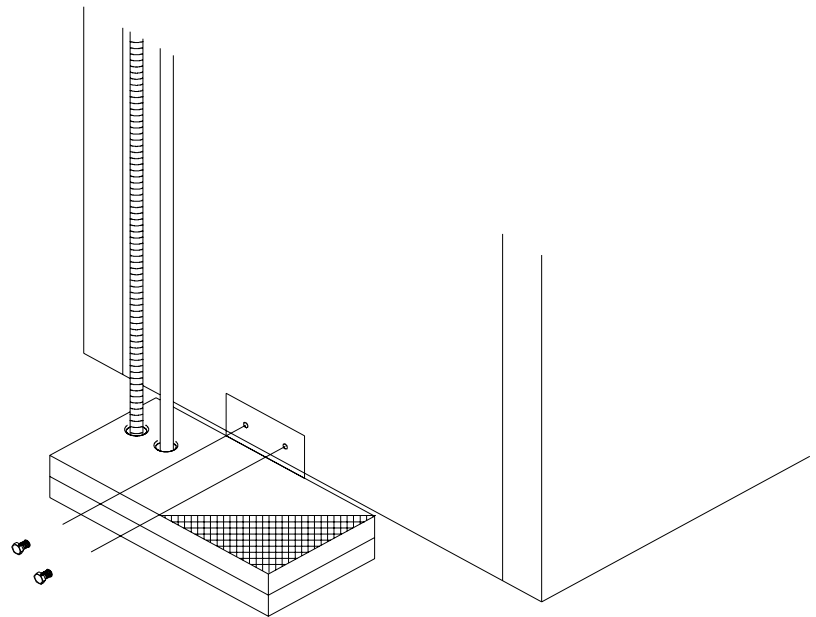

### Low Temperature Freezers – TAF Models

The **TAF - 27** models are cord connected and operate on a 15 amp, 115/60/1 circuit. The **TAF – 48** models are cord connected and operate on a 20 amp, 115/60/1 circuit. The **TAF – 74** models have two junction boxes mounted on top of the cabinet at the right rear for permanent connection to power. One junction box is labeled 115v. (black,white and green lead) ; the other is labeled 230v. (black,red and green lead). These boxes should be connected to their respective power source.

Check inside the cabinet for the power requirement for each cabinet. The label is located in the upper left hand corner. These **TAF** models are equipped with timers and electric defrost with a defrost termination and fan delay thermostat. Because of this thermostat, on initial start up the evaporator fan motors will not start and you cannot initiate a defrost until the cabinet temperature is lowered to 10°F to 20°F

The temperature thermostat on the **TAF** models does not have an “Off” position, so the condensing unit will start up immediately when the power is connected to the cabinet.

### Medium Temperature Refrigerators (TAC Models)

All **TAC** models are equipped with a 115/60/1 lead cord and plug cap. When connected to power, the condensing unit and evaporator fan (s) will start. The mullion heaters will heat and, when the door is opened, the lights will be energized.

## FINAL CHECK LIST

- A. Check setting of defrost timer:
  - 1. Four defrost/24 hours, with 30 minute fail safe. (TAF ONLY)
- B. Check operating pressures.
- C. Check electrical requirements of unit to supply voltage.
- D. Set temperature control for desired temperature range.
- E. Check sight glass for proper refrigerant charge.
- F. Check system for proper defrost settings and operation.
- G. Check condensing unit for vibrating or rubbing tubing. Dampen and clamp as required.
- H. All valves should be completely open counter-clockwise.
- I. Check packing nuts on all service valves.
- J. Replace all service valve caps and latch unit covers.

## SERVICE INSTRUCTIONS (Trouble Shooting Guide)

- 1. High head pressure and high back pressure:
  - A. Condenser coil clogged or restricted.
  - B. Condenser fan motor defective.
- 2. Low back pressure and low head pressure:
  - A. Restriction in system.
  - B. Refrigerant undercharged.
  - C. Leak in system.
- 3. Pressures normal – cabinet warm:
  - A. Coil blocked with frost or ice (see #4).
  - B. Refrigerant undercharged.
  - C. Control set too warm.
  - D. Air screen disturbance.
- 4. Coil blocked with frost or ice:
  - A. Defective temperature control.
  - B. Time clock not operating properly.
  - C. Improper time clock setting.
  - D. Defrost heater not operating.
  - E. P-trap in drain not installed.
  - F. Doors aren't sealing when closed.
  - G. Evaporator fan motor defective.
  - I. Low voltage.
- 5. Compressor starts and runs – but cycles on overload:
  - A. Low voltage.
  - B. Dropped phase (3 phase).
  - C. Overload protector defective.
  - D. High head pressure (see#1).

6. Compressor will not start – hums, but cycles on overload:
  - A. Low voltage.
  - B. Relay defective.
  - C. Overload defective.
  - D. High head pressure (see #1).

7. Special service situations:

If moisture or liquid is observed around or under a Master-Bilt cabinet, an immediate investigation should be made by qualified personnel to determine the source of moisture or liquid. The investigation made should determine if the cabinet is malfunctioning or if there is a simple housekeeping problem.

Moisture or liquid around or under a cabinet is a potential slip/fall hazard for persons walking by or working in the general area of the cabinet.

Any cabinet malfunction or housekeeping problem that creates a slip/fall hazard around or under a cabinet should be corrected immediately.

## MASTER-BILT PART NUMBERS

The table below gives Master-Bilt part numbers. Use this chart when ordering replacement parts for your **TAC/TAF** cases.

Description	TAC-27	TAC-48	TAC-74	TAF-27	TAF-48	TAF-74
Bulb	23-00343	23-00343	23-00343	23-00343	23-00343	23-00343
Bulb Holder	23-01080	23-01080	23-01080	23-01080	23-01080	23-01080
Bulb Shield	23-01465	23-01465	23-01465	23-01465	23-01465	23-01465
Caster W \ Brake	27-00591	27-00591	27-00591	27-00591	27-00591	27-00591
Casters W \ O Brake	27-00590	27-00590	27-00590	27-00590	27-00590	27-00590
Capillary Tube	11-01450	11-01450	11-01451			
Coil Defrost Heater				17-00443	17-09113	17-09076
Condensate Heater	17-00421	17-00421	17-00421	17-00421	17-00421	17-00421
Condensing Unit	01-01471	01-01471	01-01472	01-01488	01-01510	01-01487
Def. Term. Fan Delay				19-13195	19-13195	19-13195
Digital Thermometer	19-13271	19-13271	19-13271	19-13271	19-13271	19-13271
Door Frame Heater	17-09148	17-09144	17-09144	17-09449	17-09142	17-09142
Door Gasket	37-01207	37-01211	37-01211	37-01207	37-01211	37-01211
Door Handle	35-01488	35-01488	35-01488	35-01488	35-01488	35-01488
Door Hinge Assembly	A35-01501	A35-01501	A35-01501	A35-01501	A35-01501	A35-01501
Door Light Switch	35-01506	35-01506	35-01506	35-01506	35-01506	35-01506
Door Opening Trim	29-01481	29-01481	29-01481	29-01481	29-01481	29-01481
Drain Line Heater				17-00404	17-00404	17-00404
Drier	09-09308	09-09308	09-09308	09-09171	09-09506	09-09506
Evaporator Coil	07-00750	07-00135	07-00135	07-00750	07-13089	07-13089
Evaporator Fan Blade	15-01184	15-01184	15-01184	15-01184	15-01184	15-01184
Evaporator Fan Guard	25-00205	25-00205	25-00205	25-00205	25-00205	25-00205
Evaporator Fan Motor	13-00685	13-00685	13-00685	13-00685	13-00685	13-00685
Expansion Valve				09-09187	09-09542	09-09542
Female Plug				21-00577		
Front Control						
Heater Safety Control				19-01307	19-01164	19-01164
Leg	27-00558	27-00558	27-00558	27-00558	27-00558	27-00558
Pilaster	33-01408	33-01408	33-01408	33-01408	33-01408	33-01408
Pressure Control					19-13173	19-13173
Power Cord	21-00312	21-00312	21-00312	21-01454	21-01454	

Shelf Clips	33-01011	33-01011	33-01011	33-01011	33-01011	33-01011
Shelves	33-01455	33-01456	33-01456	33-01455	33-01456	33-01456
Temperature Control	19-00903	19-00903	19-00903	19-13607	19-13607	19-13607
Thermometer						
Timer				19-00817	19-00817	19-00815

## SALE AND DISPOSAL

### OWNER RESPONSIBILITY

If you sell or give away your Master-Bilt cabinet you must make sure that all safety labels and the Installation - Service Manual are included with it. If you need replacement labels or manuals, Master-Bilt will provide them free. Contact the customer service department at Master-Bilt at (800) 684-8988.

The customer service department at Master-Bilt should be contacted at the time of sale or disposal of your cabinet so records may be kept of its new location.

If you sell or give away your Master-Bilt cabinet and you evacuate the refrigerant charge before shipment, Master-Bilt recommends that the refrigerant charge be properly recovered in compliance with section 608 of the Clean Air Act effective November 1995 and in accordance with all applicable local, regional, or national standards.

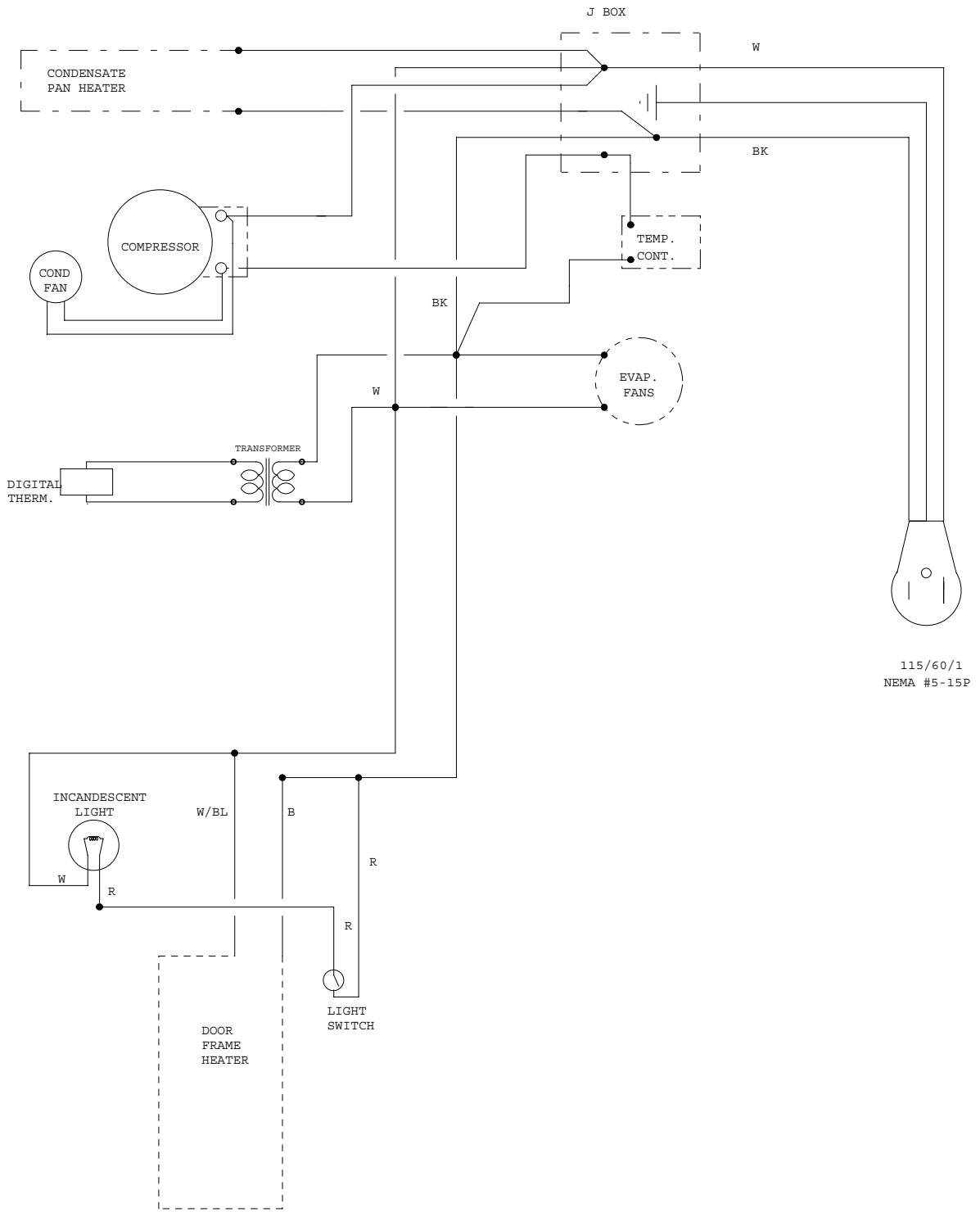

115/60/1  
NEMA #5-15P

07/19/95

WIRING DIAGRAM

TAC-27, -27HD

TC27

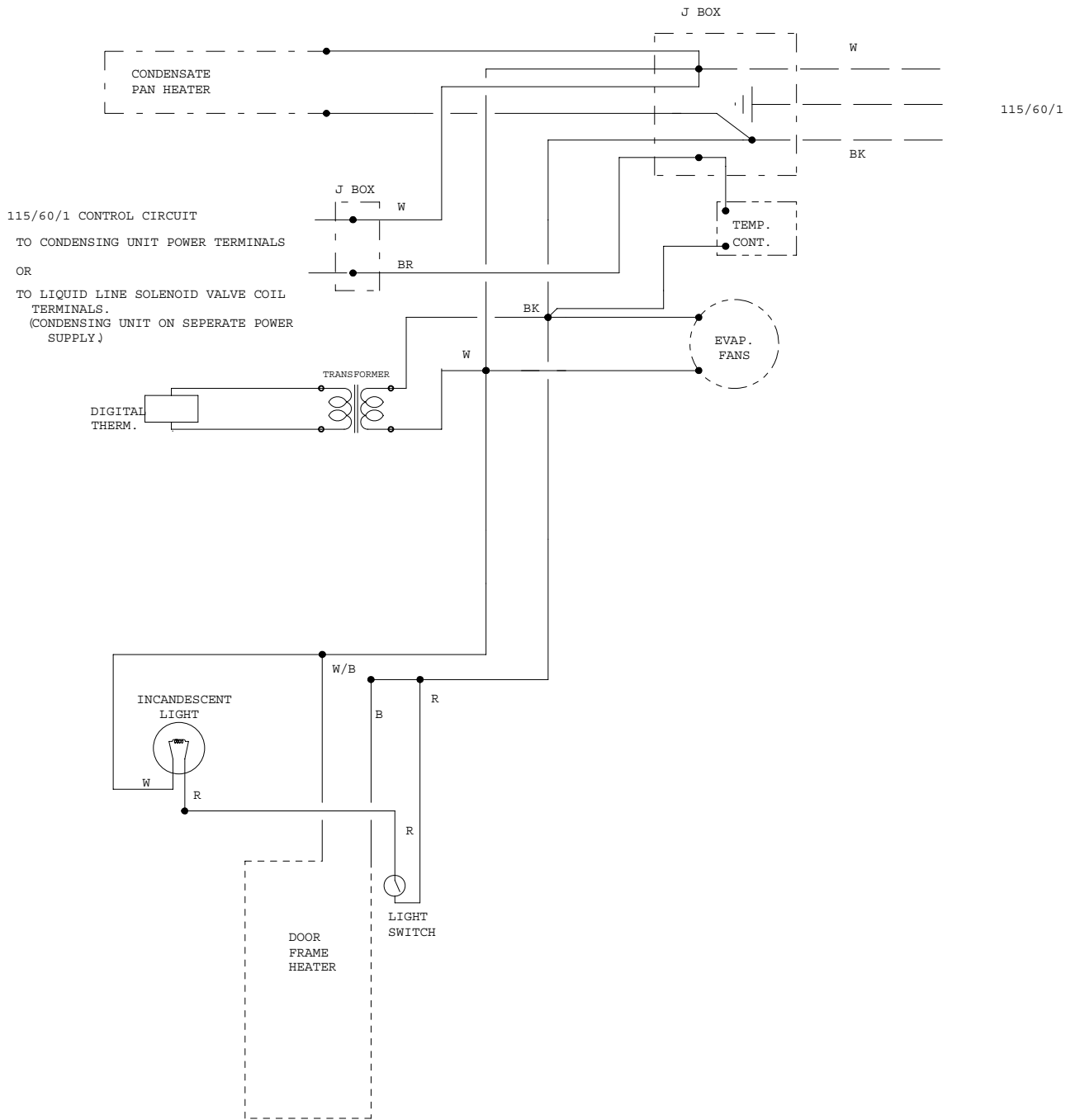

07/19/95

WIRING DIAGRAM

TAC-27-R

TC27R

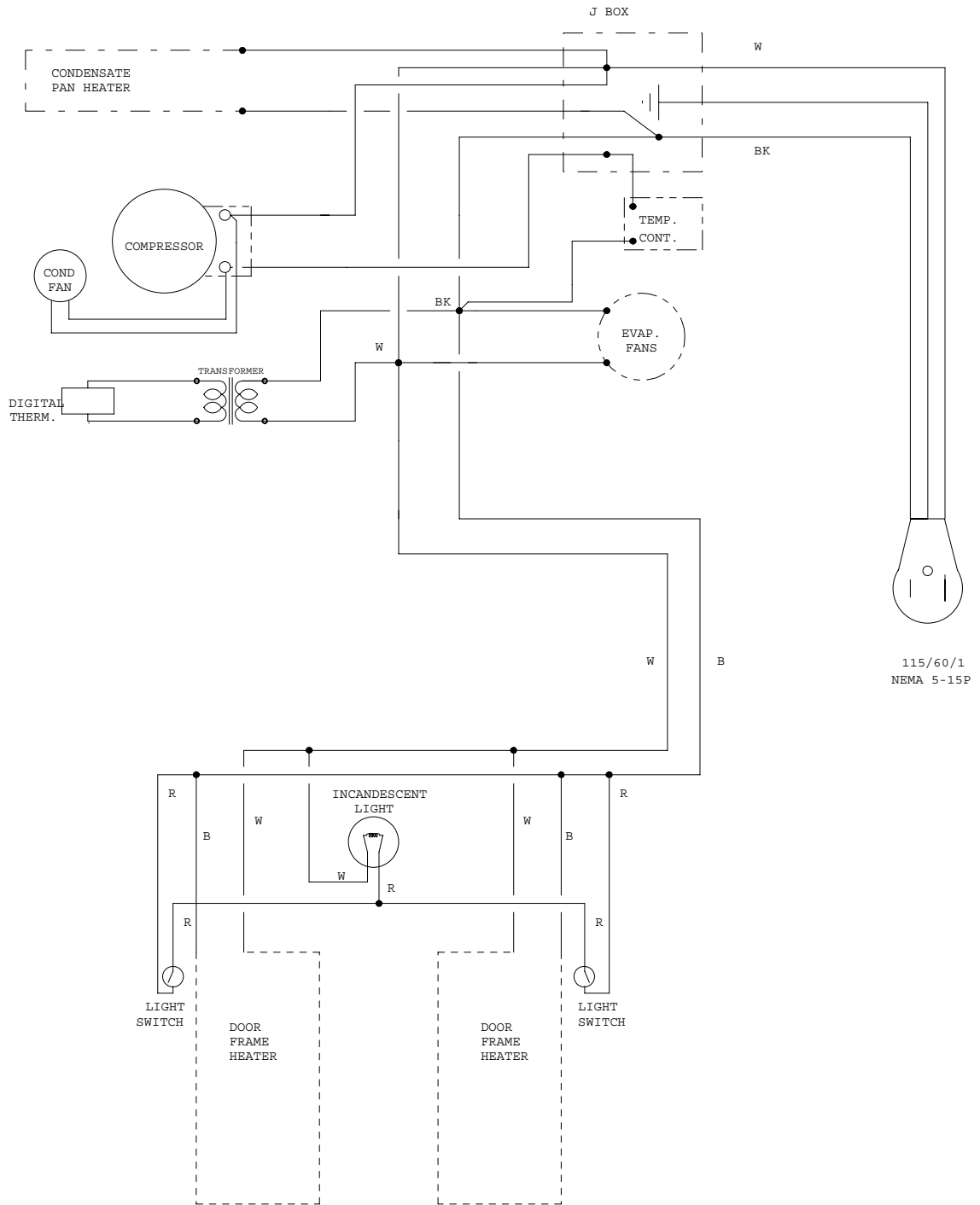

07/19/95

WIRING DIAGRAM

TAC-48, -48HD

TC48

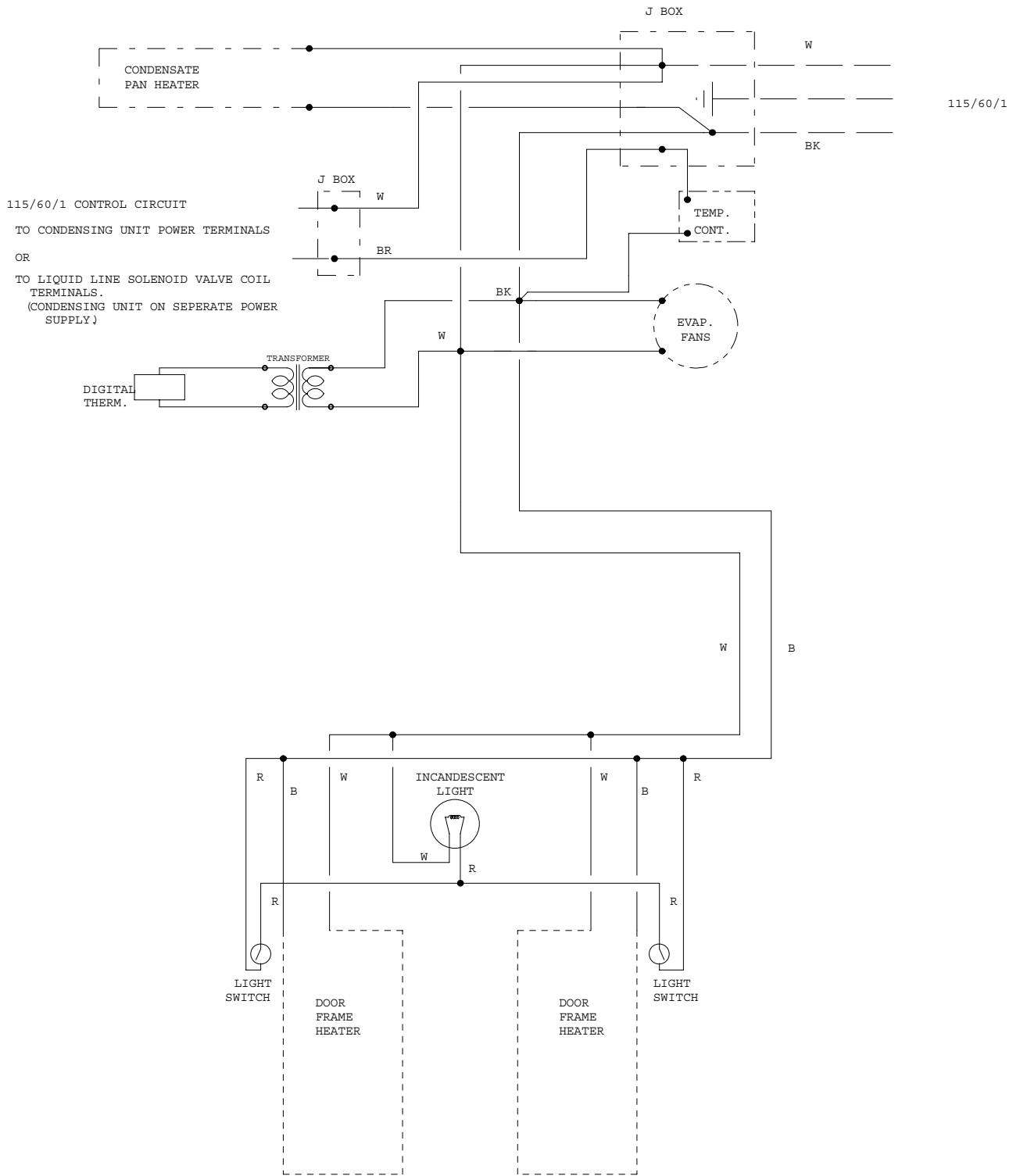

07/19/95

WIRING DIAGRAM

TAC-48-R

TC48R

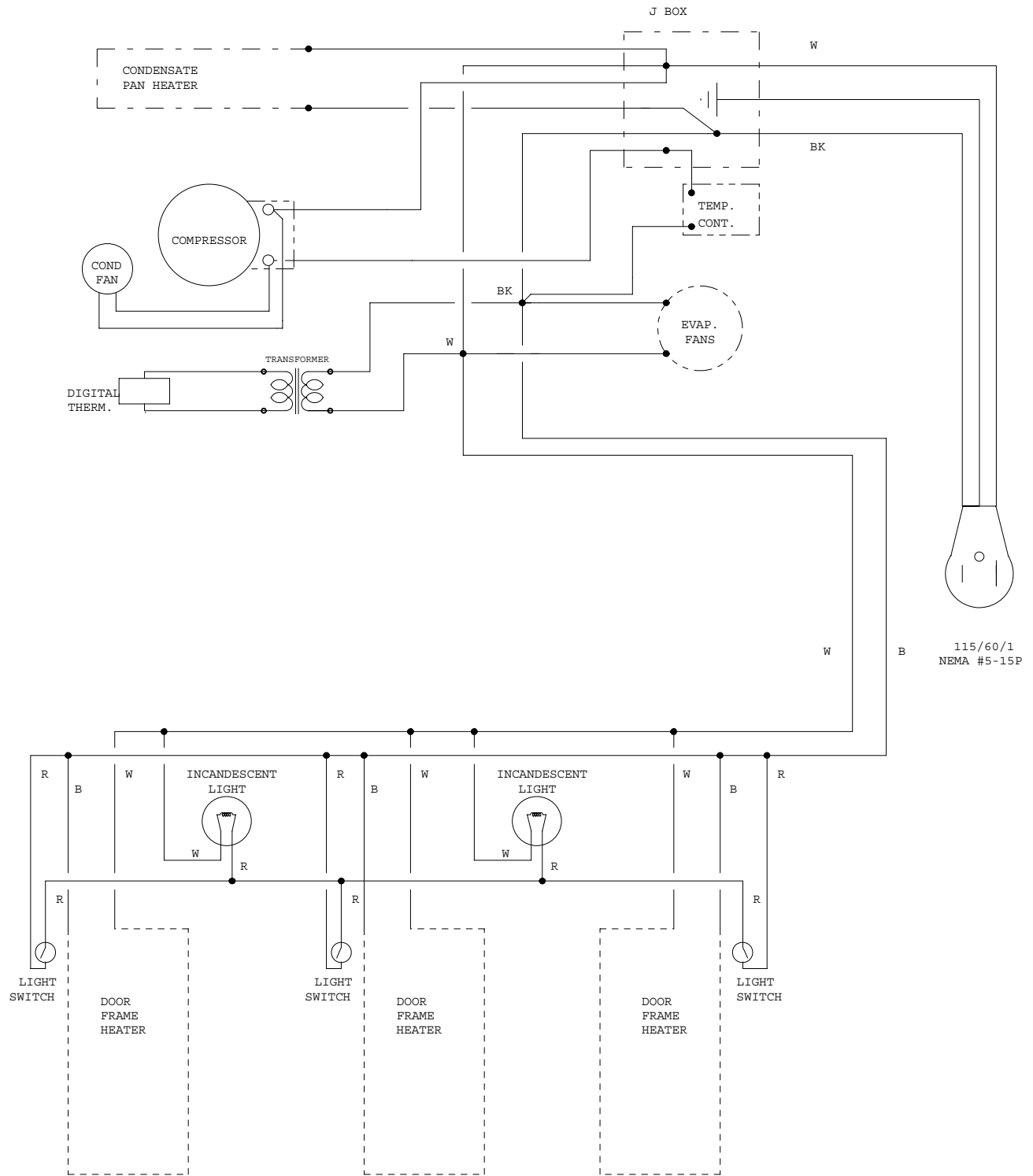

07/19/95

# WIRING DIAGRAM

# TAC-74, 74HD

TC74

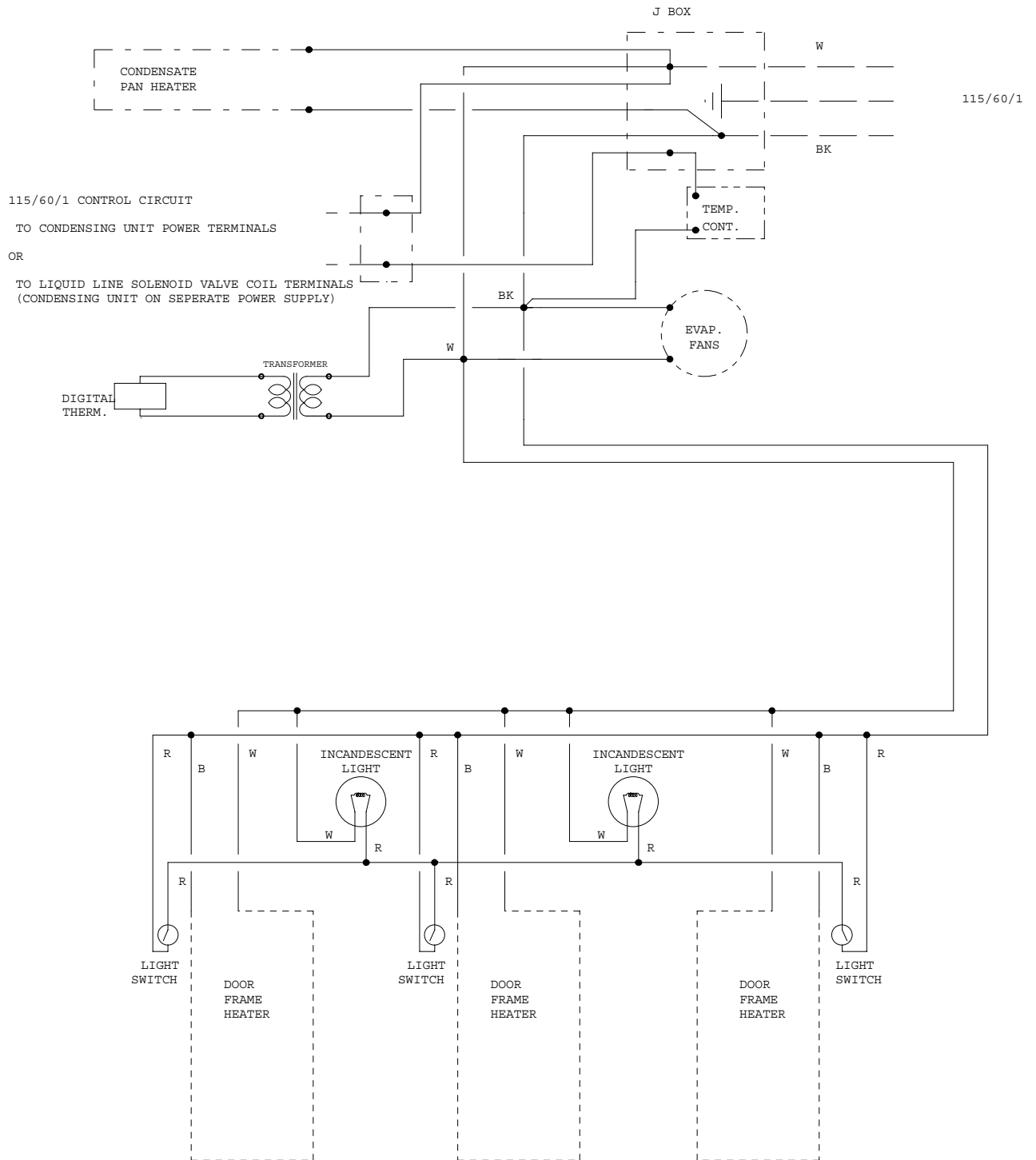

07/19/95

WIRING DIAGRAM

TAC-74 -R

TC74R

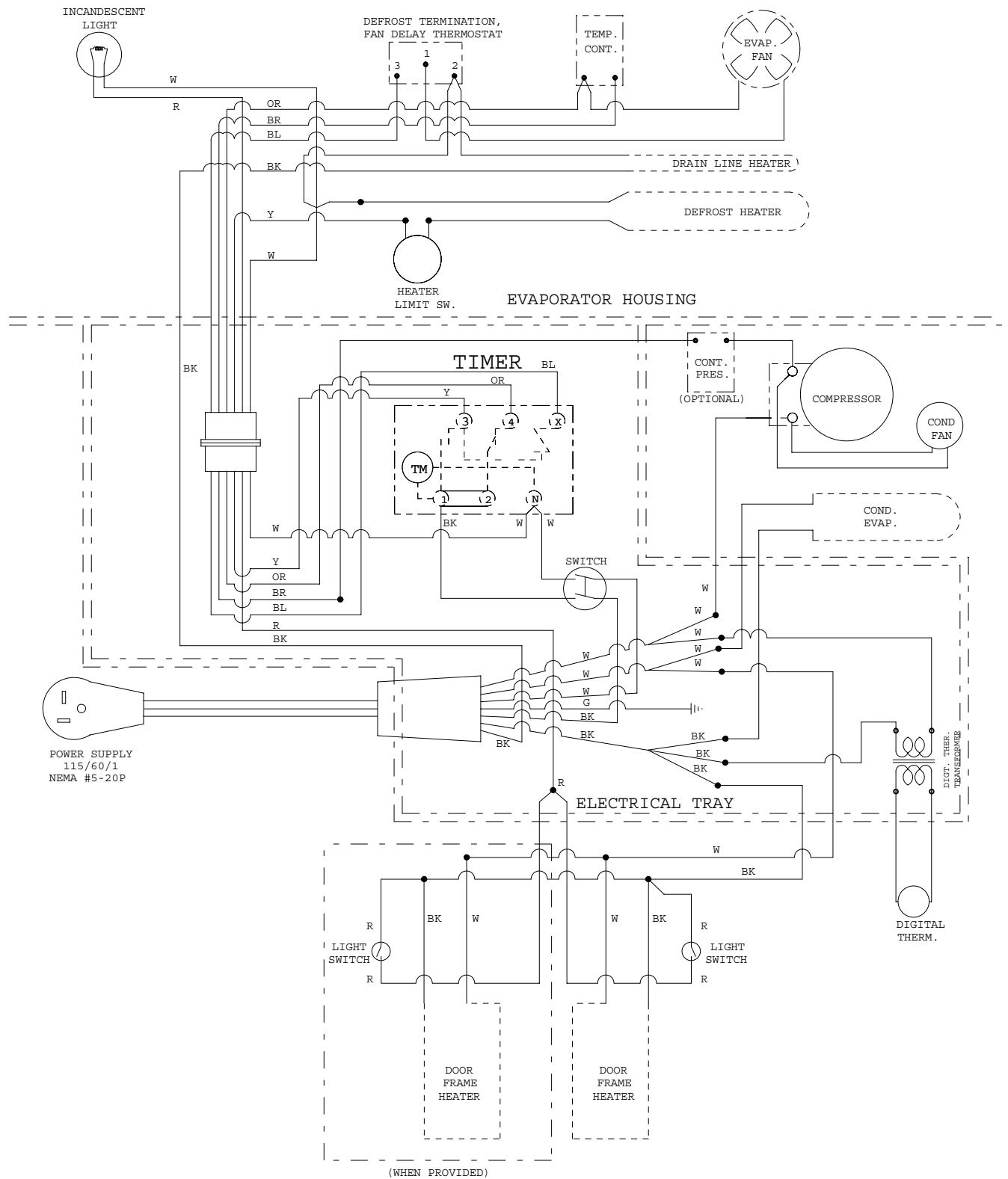

5/11/00

WIRING DIAGRAM

TAF/TUF-27, -27HD,  
TAF/TUF-27H, -27HHD

TF27-HARNS

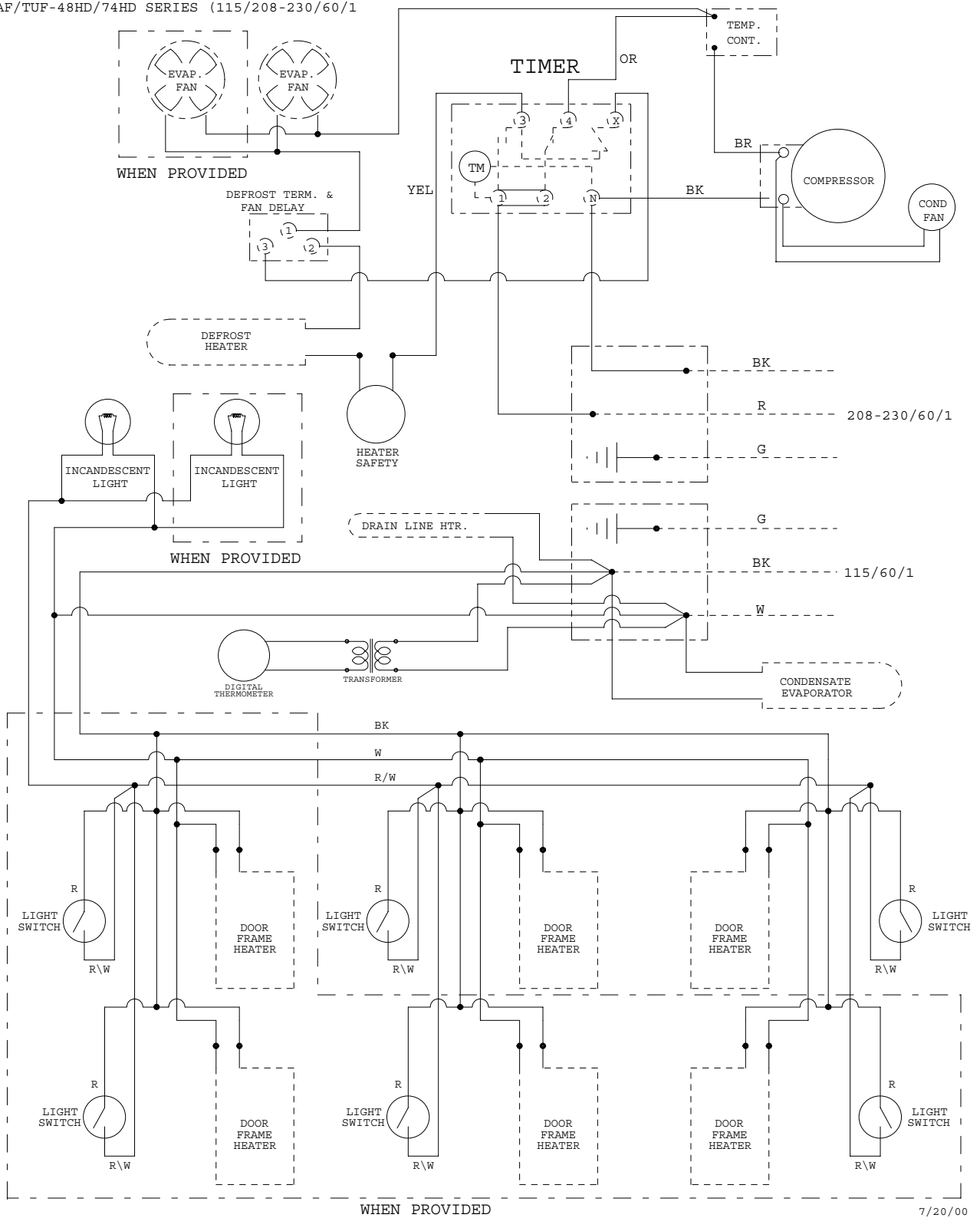

WIRING DIAGRAM TAF\TUF -48HD, -74HD  
 -4HHD, -74HHD  
 TAF-TUF-23DR-HD-HHD

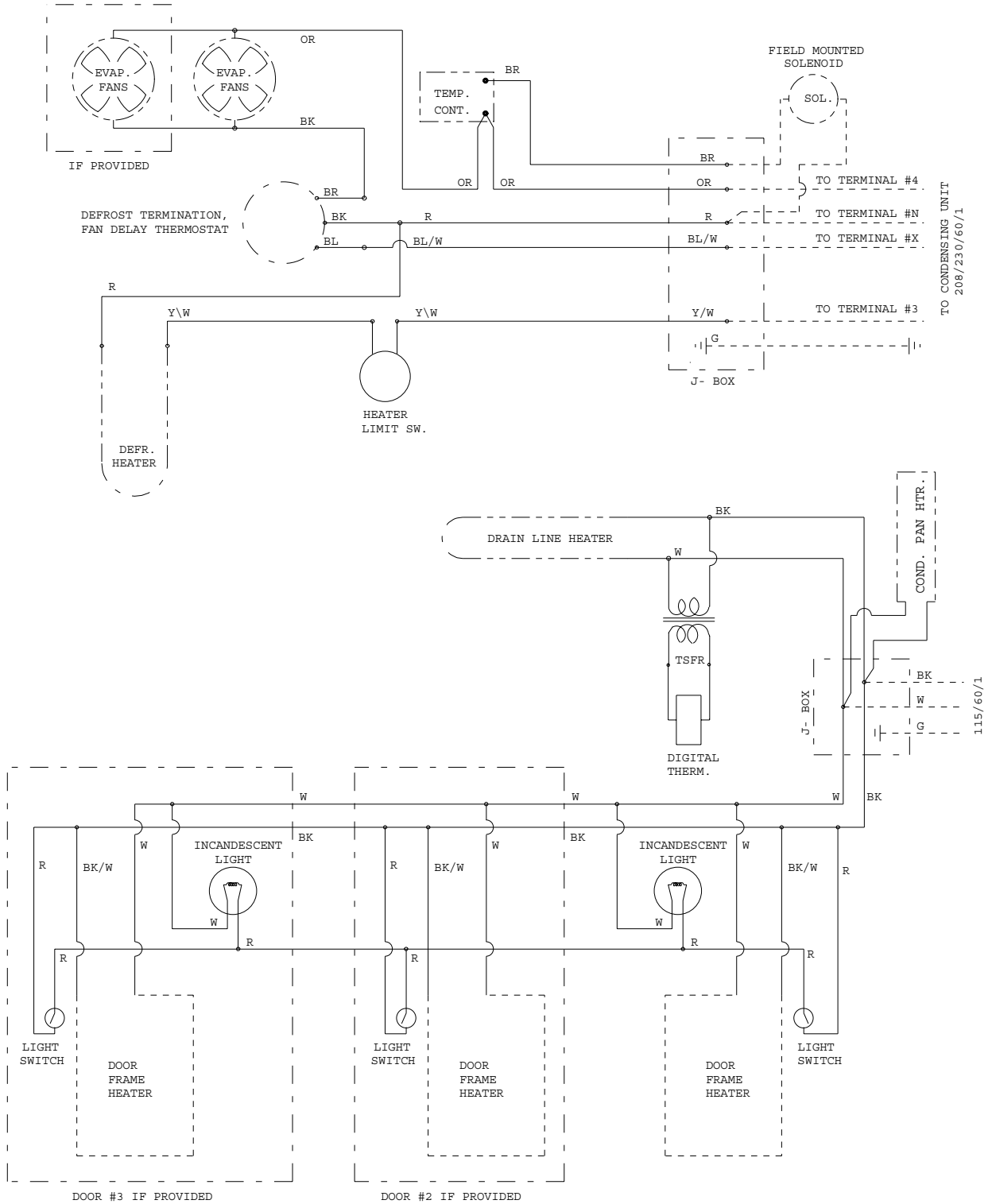

7/18/00

## WIRING DIAGRAM (TAF/TUF REMOTE/QUICK CONNECT)

TAF-TUF-123DR-R-Q