

# **MIB** MASTER-BILT® *Refrigeration Solutions*

SMBWNB-330

SMBWNB-430

SMBWNB-580

## **Installation & Operations Manual**

**Master-Bilt Products**  
908 Highway 15 North  
New Albany, MS 38652  
Phone: (800) 684-8988

PN 251-90000  
Rev 5/15/03 LPN



# TABLE OF CONTENTS

	<u>Page Numbers</u>
<b>INTRODUCTION.....</b>	<b>4</b>
<b>STORE CONDITIONS.....</b>	<b>4</b>
<b>WARNING LABELS AND SAFETY INSTRUCTIONS.....</b>	<b>5</b>
<b>PRE-INSTALLATION INSTRUCTIONS.....</b>	<b>6</b>
Inspection for Shipping Damage.....	6
<b>INSTALLATION INSTRUCTIONS.....</b>	<b>6</b>
General Instructions.....	6
Electrical and Refrigeration Data.....	7
Cleaning.....	8
<b>STARTING PROCEDURE.....</b>	<b>8</b>
<b>FINAL CHECK LIST.....</b>	<b>8</b>
<b>SERVICE INSTRUCTIONS.....</b>	<b>9</b>
<b>MASTER-BILT PART NUMBERS.....</b>	<b>10</b>
<b>ACCESSORIES LIST.....</b>	<b>11</b>
<b>SALE AND DISPOSAL.....</b>	<b>11</b>
<b>WIRING DIAGRAMS.....</b>	<b>12-14</b>

## INTRODUCTION

Thank you for purchasing a Master-Bilt cabinet. This manual contains important instructions for installing, using and servicing a Master-Bilt **SMB/WMB** case. A parts list is included in with this manual. Read all these documents carefully before installing or servicing your equipment.

## STORE CONDITIONS

The Master-Bilt **SMB/WMB** cases are designed to operate in the controlled environment of an air conditioned store. The store temperature should be at or below 75°F and a relative humidity of 55% or less. At higher temperature or humidity conditions, the performance of these cases may be affected and the capacity diminished. It is not uncommon in a newly constructed store for the temperature and humidity to be above design conditions. These excessive conditions may produce sweating in the case until the store is operational and the ambient environment is more desirable.

The Master-Bilt **SMB/WMB** should not be positioned where it is directly exposed to rays of sun or near a direct source of radiant heat or air flow. This will adversely affect the case and will result in poor performance.

If this case is to be located against a wall there should be at least 4" space between the wall and the back of the case. This space will allow for the circulation of air behind the case which will prevent condensation on the exterior surfaces and allow the refrigeration system to discharge air properly.



**Read this manual before installing your cabinet. Keep the manual and refer to it before doing any service on the equipment. Failure to do so could result in personal injury or damage to the cabinet.**



**Improper or faulty hook-up of electrical components of the refrigeration units can result in severe injury or death.**

**All electrical wiring hook-ups must be done in accordance with all applicable local, regional or national standards.**



**Installation and service of the refrigeration and electrical components of the cabinet must be performed by a refrigeration mechanic and/or a licensed electrician.**

The portions of this manual covering refrigeration and electrical components contain technical instructions intended only for persons qualified to perform refrigeration and electrical work.

This manual cannot cover every installation, use or service situation. If you need additional information, call or write us:

Customer Service Department  
Master-Bilt Products  
Highway 15 North  
New Albany, MS 38652  
Phone (800) 684-8988  
Fax (800) 684-8988

## WARNING LABELS AND SAFETY INSTRUCTIONS



This symbol is the safety-alert symbol. When you see this symbol on your cabinet or in this manual, be alert to the potential for personal injury or damage to your equipment.

Be sure you understand all safety messages and always follow recommended precautions and safe operating practices.



### NOTICE TO EMPLOYERS

**You must make sure that everyone who installs, uses or services your cabinet is thoroughly familiar with all safety information and procedures.**

Important safety information is presented in this section and throughout this section and throughout the manual. The following signal words are used in the warnings and safety messages:

**DANGER:** Severe injury or death will occur if you ignore the message.

**WARNING:** Severe injury or death can occur if you ignore the message.

**CAUTION:** Minor injury or damage to your cabinet can occur if you ignore the message.

**NOTICE:** This is important installation, operation or service information. If you ignore the message, you may damage your cabinet.

**The warning and safety labels shown throughout this manual are placed on your Master-Bilt Products cabinet at the factory. Follow all warning label instructions. If any warning or safety labels become lost or damaged, call your customer service department at (800) 684-8988 for replacements.**

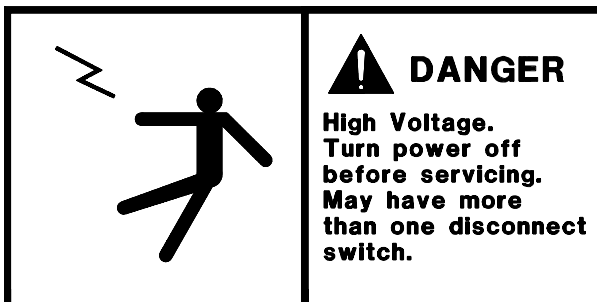

*This label is located on top of the electrical control label and on the wiring channel.*

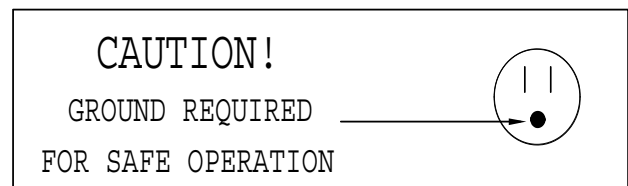

*This label is attached to the cabinet power cord on models with a power cord.*

## PRE-INSTALLATION INSTRUCTIONS

### INSPECTION FOR SHIPPING DAMAGE

You are responsible for filing all freight claims with the delivering truck line. Inspect all cartons and crates for damage as soon as they arrive. If damage is noted to shipping crates or cartons or if a shortage is found, note this on the bill of lading (all copies) prior to signing.

If damage is discovered when the cabinet is uncrated, immediately call the delivering truck line and follow up the call with a written report indicating concealed damage to your shipment. Ask for an immediate inspection of your concealed damage item. Crating material must be retained to show the inspector from the truck line.

## INSTALLATION INSTRUCTIONS

### GENERAL INSTRUCTIONS

1. Be sure the equipment is properly installed by competent service people.
2. Keep the equipment clean and sanitary so it will meet your local sanitation codes.
3. Rotate your stock so that older stock does not accumulate. This is especially important for ice cream. A "First-In, First-Out" rotation practice will keep the products in good salable condition.
4. Do not place product in the case for at least 6 hours after it is started.
5. Stock cases as quickly as possible, exposing only small quantities to store temperatures for short periods of time.
6. When replacing burned out fluorescent tubes, be sure that the electrical power to the lighting circuit is turned off.

### NOTICE TO STORE OWNERS / MANAGERS

**Moisture or liquid around or under the cabinet is a potential slip/fall hazard for persons walking by or working in the general area of the cabinet. Any cabinet malfunction or housekeeping problem that creates a slip/fall hazard around or under the cabinet should be corrected immediately.**

If moisture or liquid is observed around or under a Master-Bilt cabinet, an immediate investigation should be made by qualified personnel to determine the source of the moisture or liquid. The investigation should determine if the cabinet is malfunctioning or if there is a drain pipe leaking.

## ELECTRICAL



### WARNING

Before servicing electrical components in the case or the doors or door frames make sure all power to case is off. Always use a qualified technician.

## ELECTRICAL AND REFRIGERATION DATA

Description	SMB-330	SMB-430 WMB-430	SMB-580 WMB-580	SMB-870 WMB-870	FMB-430	FMB-580	FMB-870
Condensing Unit	Tecumseh AE3440-AA	Tecumseh AK9441-AA	Tecumseh AK9441-AA	Tecumseh AJ4492-AD	Tecumseh AE3440-AA	Tecumseh AK9441-AA	Tecumseh AK9441-AA
H.P.	1/3	1/2	1/2	3/4	1/3	1/2	1/2
Voltage	115/60/1	115/60/1	115/60/1	115/60/1	115/60/1	115/60/1	115/60/1
Total Amps	11.6	15.0	15.0	22.5	11.6	22.5	15.0
Refrigerant Charge	13 oz.	21 oz.	22 oz.	23 oz.	13 oz.	23 oz.	23 oz.
Capillary Tube	10 ft. .049 I.D.	10 ft. .054 I.D.	10 ft. .054 I.D.	10 ft. .080 I.D.	10 ft. .049 I.D.	10 ft. .054 I.D.	8 ft. .059 I.D.
Temperature Control	Cutler-Hammer 9540N143	Cutler-Hammer 9540N143	Cutler-Hammer 9540N143	Cutler-Hammer 9540N143	Ranco A30-1762	Ranco A30-1762	Ranco A30-1762
Operating Pressure @ 85° Ambient	H.P. 150# S.P. 18#	H.P. 150# S.P. 18#	H.P. 150# S.P. 18#	H.P. 150# S.P. 18#	H.P. 150# S.P. 18#	H.P. 150# S.P. 18#	H.P. 150# S.P. 18#
Condensate Pan Heater	300 Watts 115 Volts	300 Watts 115 Volts	300 Watts 115 Volts	300 Watts 115 Volts	300 Watts 115 Volts	300 Watts 115 Volts	300 Watts 115 Volts

## INSTALLATION INSTRUCTIONS

To comply with Sanitation requirements, this cabinet must be mounted on casters, legs (6" high min.) or the base must be sealed to the floor. The minimum clearance allow at least 4" space between the wall and the back of the case. This space will allow for the circulation of air behind the case which will prevent condensation on the exterior surfaces and allow the refrigeration system to discharge air properly.

### CLEANING



Clean cabinet with a mild detergent and warm water. **DO NOT USE ABRASIVE CLEANERS.** Glass doors should be cleaned with a glass cleaner.

### STARTING PROCEDURE

#### Medium Temperature Refrigerators

All **SMB/WMB** models are equipped with a cord and plug cap. When connected to power, the condensing unit and evaporator fan (s) will start and the door heaters will heat.

### FINAL CHECK LIST

- A. Check operating pressures.
- B. Check electrical requirements of unit to supply voltage.
- C. Set temperature control for desired temperature range.
- D. Check system for proper defrost operation.
  - 1. Verify setting of two 34 minutes defrost per 24 hours.
- E. Check system settings and operation.
- F. Check condensing unit for vibrating or rubbing tubing. Dampen and clamp as required.
- G. All valves should be completely open counter-clockwise.
- H. Check packing nuts on all service valves.
- I. Check sight glass for proper refrigerant charge, if provided.
- J. Replace all service valve caps.

## SERVICE INSTRUCTIONS (Trouble Shooting Guide)

1. High head pressure and high back pressure:
  - A. Condenser coil clogged or restricted.
  - B. Condenser fan motor defective.
  - C. Air discharge in rear of cabinet restricted
2. Low back pressure and low head pressure:
  - A. Restriction in system.
  - B. Refrigerant undercharged.
  - C. Leak in system.
3. Pressures normal – cabinet warm:
  - A. Coil blocked with frost or ice (see #4).
  - B. Refrigerant undercharged.
  - C. Control set too warm.
4. Coil blocked with frost or ice:
  - A. Defective temperature control.
  - B. Doors aren't sealing when closed.
  - C. Evaporator fan motor defective.
  - D. Low voltage.
5. Compressor starts and runs – but cycles on overload:
  - A. Low voltage.
  - B. Overload protector defective.
  - C. High head pressure (see#1).
6. Compressor will not start – hums, but cycles on overload:
  - A. Low voltage.
  - B. Relay defective.
  - C. Overload defective.
  - D. High head pressure (see #1).

## MASTER-BILT PART NUMBERS

The table below gives Master-Bilt part numbers. Use this chart when ordering replacement parts for your **SMB/WMB** cases.

Description	SMB-330	SMB-430 WMB-430	SMB-580 WMB-580	SMB-870 WMB-870	FMB-430	FMB-580	FMB-870
Ballast	23-00155	23-00155	23-00155	23-00155	23-00155	23-00155	23-00155
Bulb Shield	23-01464	23-01464	23-01464	23-01464	23-01464	23-01464	23-01464
Capillary Tube	11-01226	11-01227	11-01227	11-01310	11-01226	11-01227	11-01228
Condensate Heater	17-00399	17-00399	17-00399	17-00380	17-00399	17-00399	17-00380
Condensing Unit	01-01035	01-01037	01-01037	01-01342	01-01035	01-01037	01-01037
Door Frame Heater	17-09064	17-09065	17-09066	17-09067	17-09065	17-09066	17-09067
Door Glass	31-01460	31-01461	31-01462	31-01463	31-01461	31-01462	31-01463
Drier	09-00810	09-00810	09-00810	09-00811	09-33810	09-00810	09-00810
Evaporator Coil	07-00135	07-00135	07-00135	07-00134	07-00135	07-00134	07-00134
Evaporator Fan Blade	15-01184	15-01184	15-01184	15-01184	15-01184	15-01184	15-01184
Evaporator Fan Guard	25-00205	25-00205	25-00205	25-00205	25-00205	25-00205	25-00205
Evaporator Fan Motor	13-00685	13-00685	13-00685	13-00685	13-00685	13-00685	13-00685
Flourecent Lamp	23-00325	23-00327	23-00327	23-00327	23-00327	23-00327	23-00327
Lampholder/ Starter Base	23-01127	23-01127	23-01127	23-01127	23-01127	23-01127	23-01127
Lampholder	23-01128	23-01128	23-01128	23-01128	23-01128	23-01128	23-01128
Pilaster	33-01408	33-01408	33-01408	33-01408			
Pilaster Clip	33-01011	33-01011	33-01011	33-01011			
Plate Glass Shelf					31-01280	31-01281	31-01280
Power Cord					21-00524	21-00524	21-01218
Starter	23-01093	23-01093	23-01093	23-01093	23-01093	23-01093	23-01093
Temperature Control	19-00903	19-00903	19-00903	19-00903	19-00884	19-00884	19-00884
Timer				19-00818			
Toggle Switch	19-01071	19-01071	19-01071	19-01071	19-01071	19-01071	19-01071
Wire Shelf	33-01381	33-00106	33-00108	33-00106			

## ACCESSORIES LIST

Description	SMB-330	SMB-430 WMB-430	SMB-580 WMB-580	SMB-870 WMB-870	FMB-430	FMB-580	FMB-870
<b>Casters</b>							
Set of four, 3" diameter	A251-11140	A251-11140			A251-11140		
Set of six, 3" diameter			A253-11140			A253-11140	
Set of six, 3" diameter				A254-11140			A254-11140
<b>Locks</b>							
Barrel Type	35-01474	35-01474	35-01474	35-01474	35-01474	35-01474	35-01474
<b>Shelving</b>							
Welded Wire, White Epoxy	33-01381	33-00106	33-00108	33-00106	33-00106	33-00108	33-00106
<b>Shelving</b>							
Welded Wire, Black Epoxy for WMB Series		33-01541 (WMB-430 Only)	33-01542 (WMB-580 Only)	33-01541 (WMB-870 Only)			
<b>Glass Shelving for FMB Series</b>							
					31-01280	31-01281	31-01280

## SALE AND DISPOSAL

### OWNER RESPONSIBILITY

If you sell or give away your Master-Bilt cabinet you must make sure that all safety labels and the Installation - Service Manual are included with it. If you need replacement labels or manuals, Master-Bilt will provide them free. Contact the customer service department at Master-Bilt at (800) 684-8988.

The customer service department at Master-Bilt should be contacted at the time of sale or disposal of your cabinet so records may be kept of its new location.

If you sell or give away your Master-Bilt cabinet and you evacuate the refrigerant charge before shipment, Master-Bilt recommends that the refrigerant charge be properly recovered in compliance with section 608 of the Clean Air Act effective November 1995 and in accordance with all applicable local, regional, or national standards.

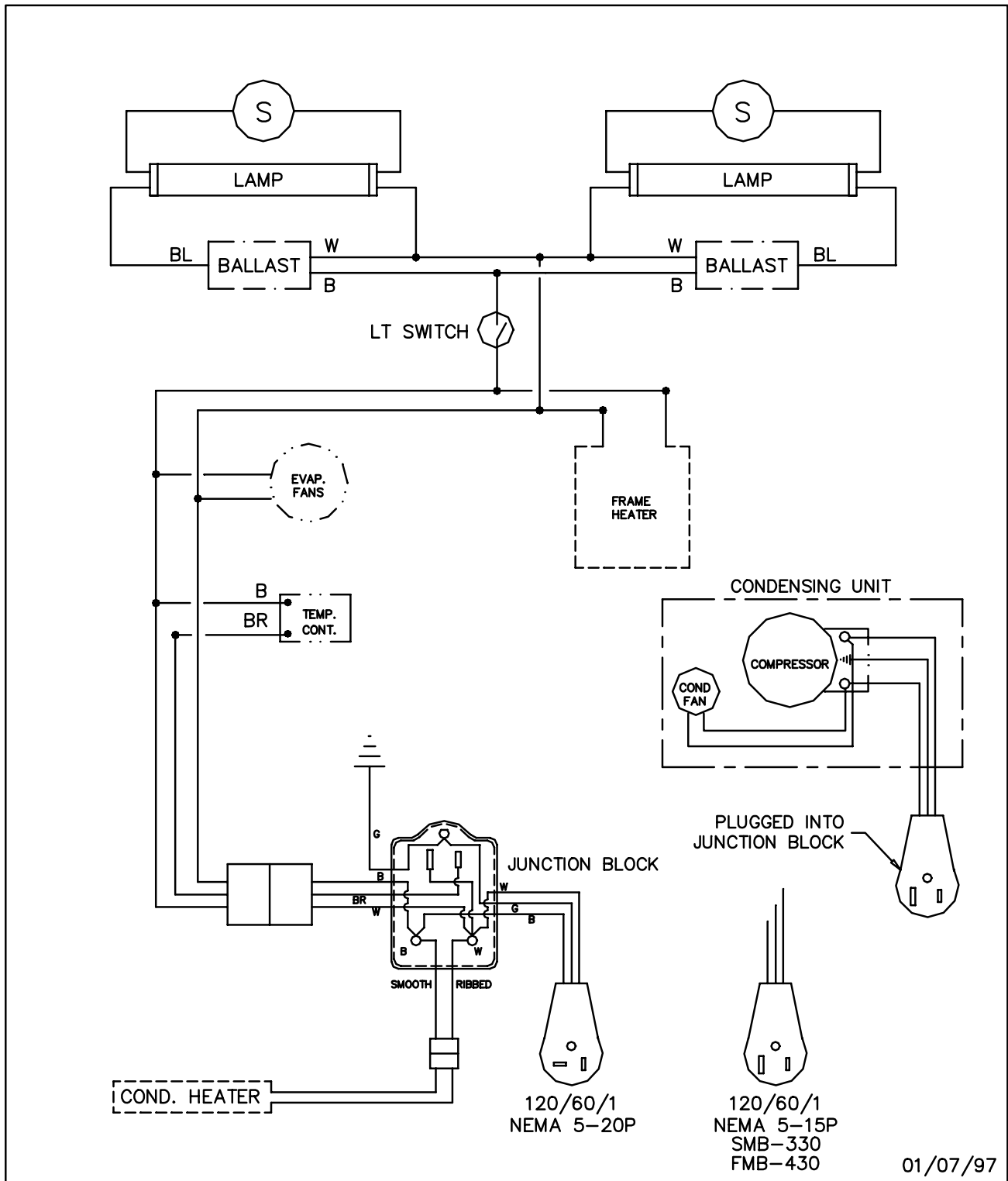

01/07/97

# WIRING DIAGRAM

SMB-330	430	580
WMB-430	580	
FMB-430	580	

SWFMB-35

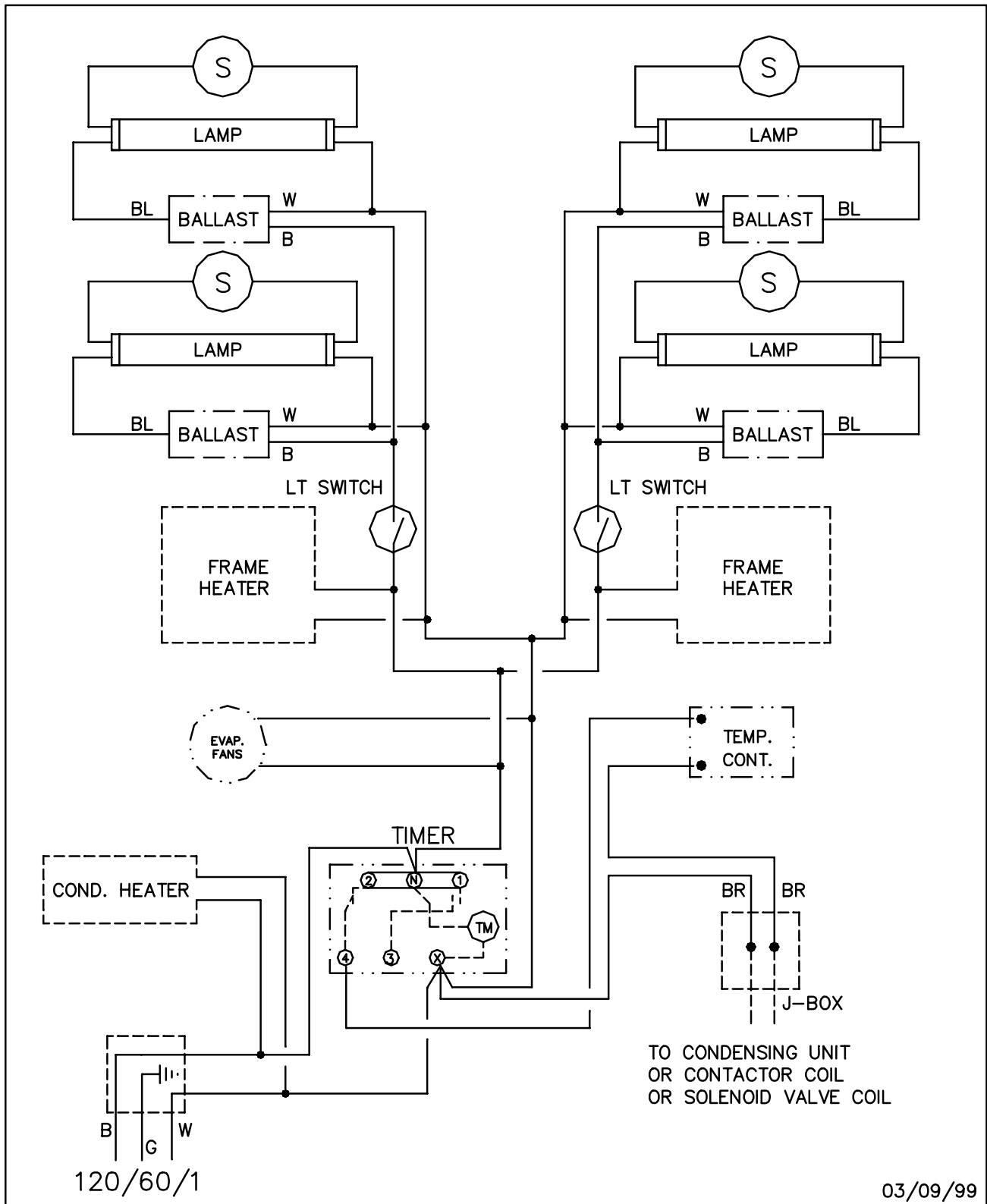

WIRING DIAGRAM SMB-870R  
WMB-870R

SMB870R

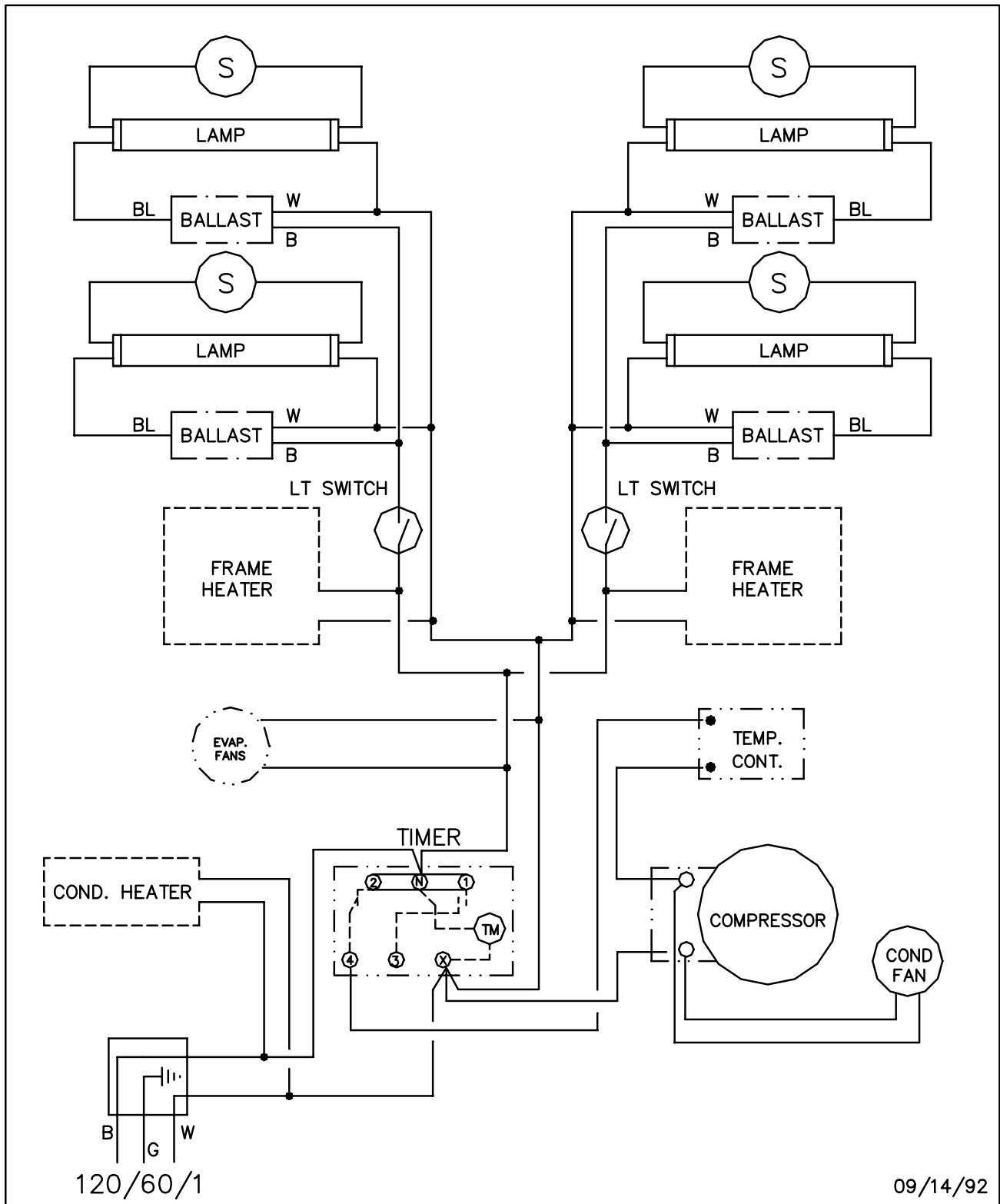

WIRING DIAGRAM

SMB-870  
WMB-870

09/14/92

SMB-870