

Pizza Prep Table Refrigerator Installation and Operation Manual

Please read this manual completely before attempting to install or operate this equipment!



PPT-67

Full Stainless Steel Visible Exterior

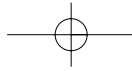

CONTENTS

	PAGE
SPECIFICATIONS	2
SERIAL NUMBER	2
CUTTING BOARD & BRACKETS Installation Schematic Diagram.....	3
INSTALLATION OF CASTORS	4
INSTALLATION OF HOOD LID	4
HOW TO CLEAN THE PAN AIR DUCT PANEL	6
HOW TO OPEN AND CLOSE THE HOOD LID	6
INSTALLATION.....	7
CLEANING & CAUTION.....	8
BASIC OPERATION.....	9
BEFORE REQUESTING SERVICE	10
WARRANTY	11~13

SPECIFICATIONS

Pizza Prep Table

MODEL	COMP H.P.	V/Hz	REFRIGERANT	AMPS	WEIGHT
PPT-67	5/8	115V/60Hz	R-134a	10.4A	395lbs

SERIAL NUMBER

The serial number is located on the rating label which is on the left interior wall.

Please retain the unit's serial number for service purpose.

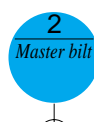

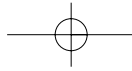

CUTTING BOARD & BRACKETS Installation Schematic Diagram

Part List

NO	PART NAME	SPECIFICATION	QUANTITIES
1	CUTTING BOARD	67'* 19 5/16'* 1/2'	1
2	CUTTING BOARD BRACKET	SUS304	2
3	LID BRACKET LEFT	SUS304	1
4	LID BRACKET CENTER	SUS304	1
5	LID BRACKET RIGHT	SUS304	1
6	CUTTING BOARD KEY SCREW	M5*L6.5	2
7	SCREW	M4*10	10

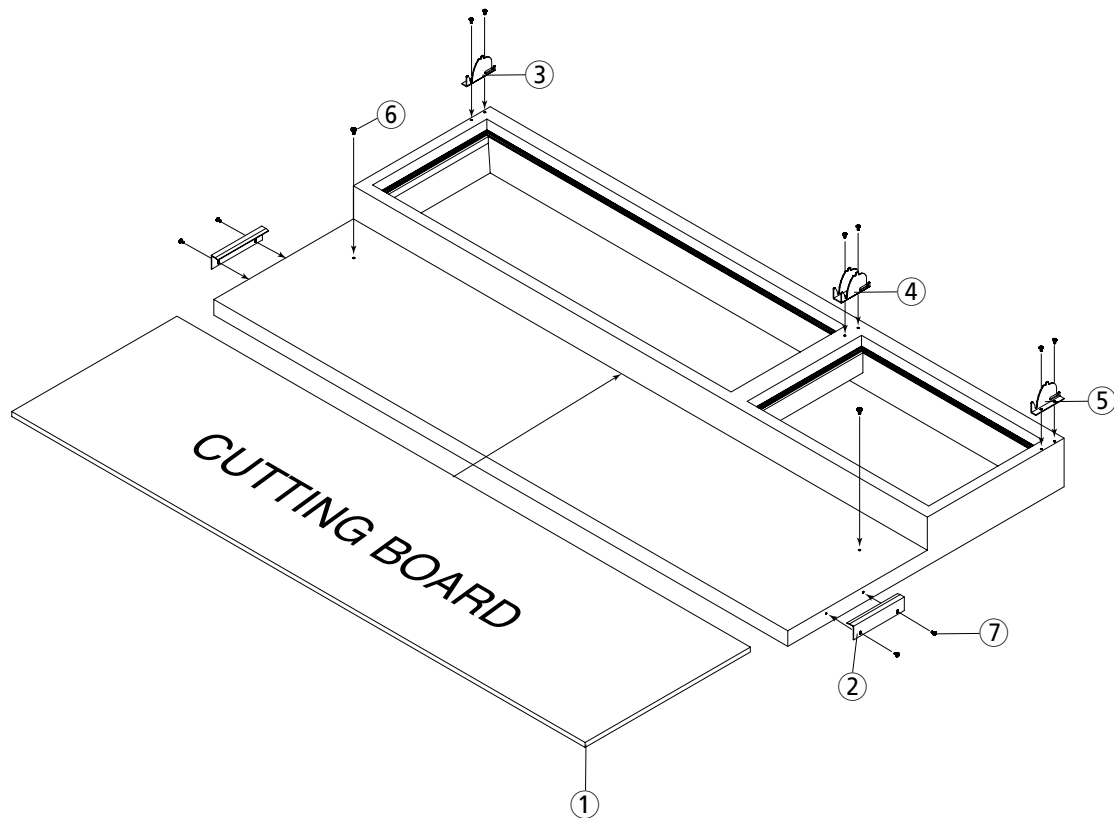

* Assemble CUTTING BOARD and BRACKETS as above drawing.

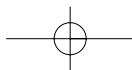

INSTALLATION OF CASTOR AND CASTOR BRAKE

- 1) Screw the castor (in rear side) and the castor brakes (in front side) by using castor wrench.
- 2) Use the castor shims to level the cabinet, if necessary, by inserting them to stems of the castors.

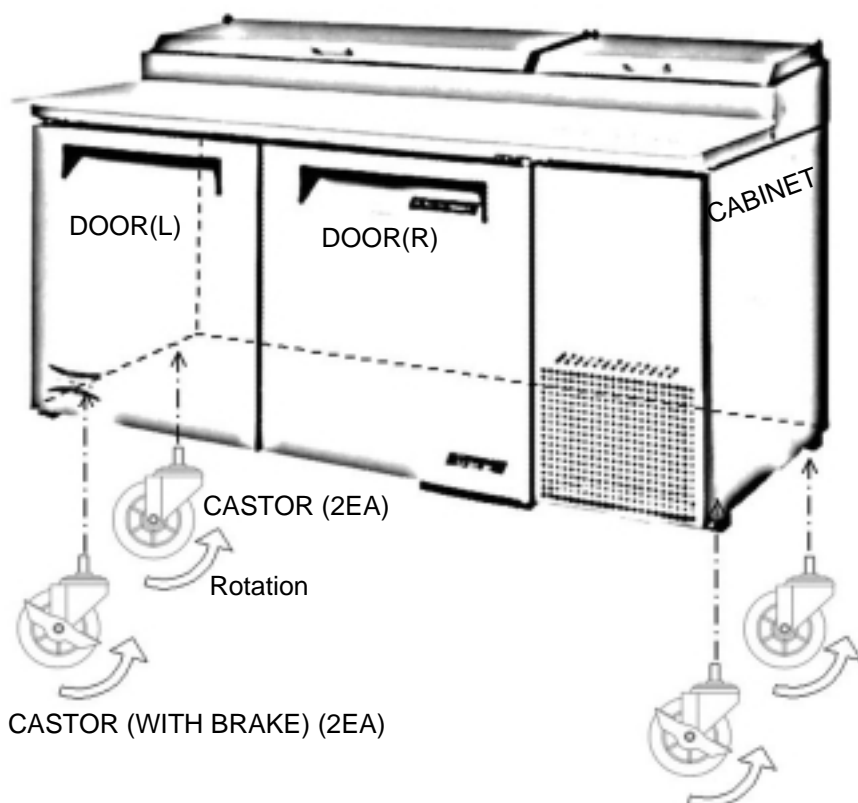

INSTALLATION OF HOOD LID

- 1) HANDLE ASSEMBLY

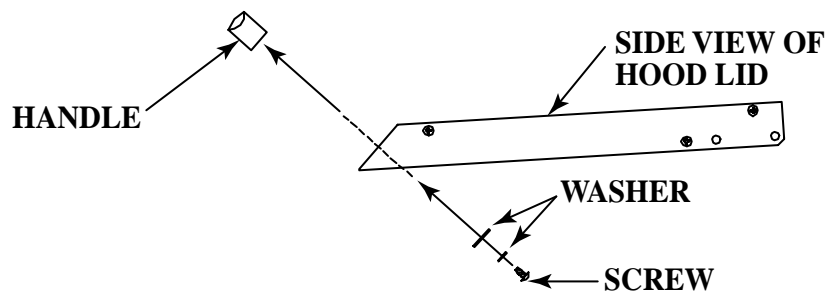

- * Assemble the handle with washers and screws as above drawing.

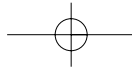

INSTALLATION OF HOOD LID

2) Assemble HOOD LID BRACKET like drawing below.

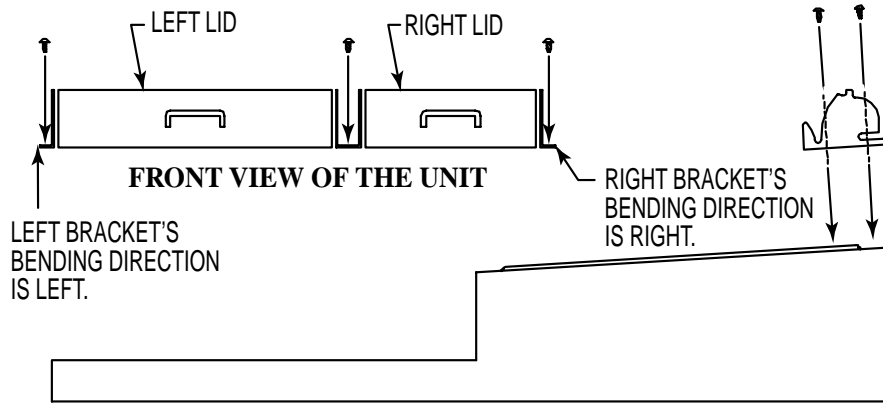

There are 3 kinds of bracket. They are for left, middle, right position.

3) Insert HOOD LID SHAFT like drawing below.

* Insert shaft and pull hood lid with parallel like arrow direction.

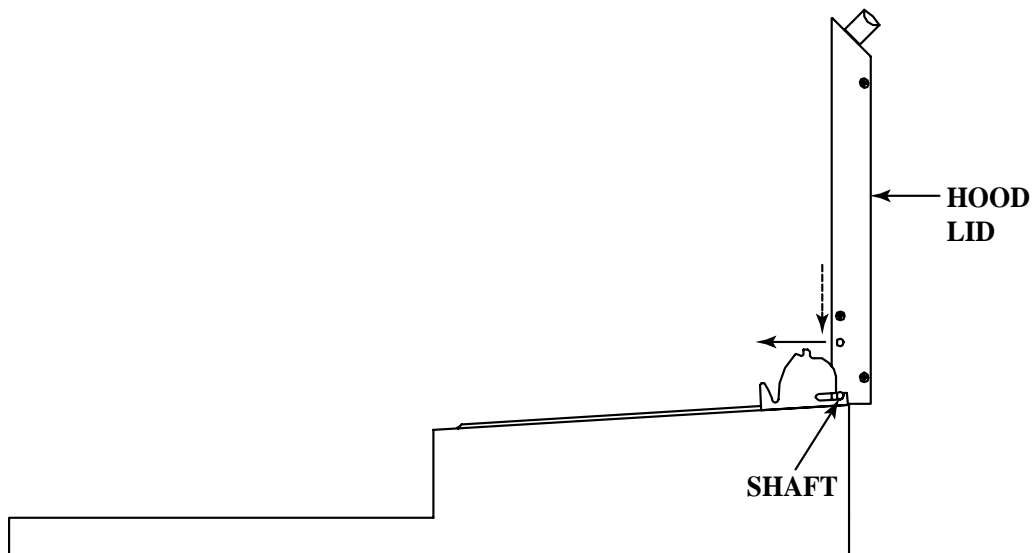

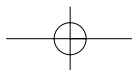

HOW TO CLEAN THE PAN AIR DUCT PANEL

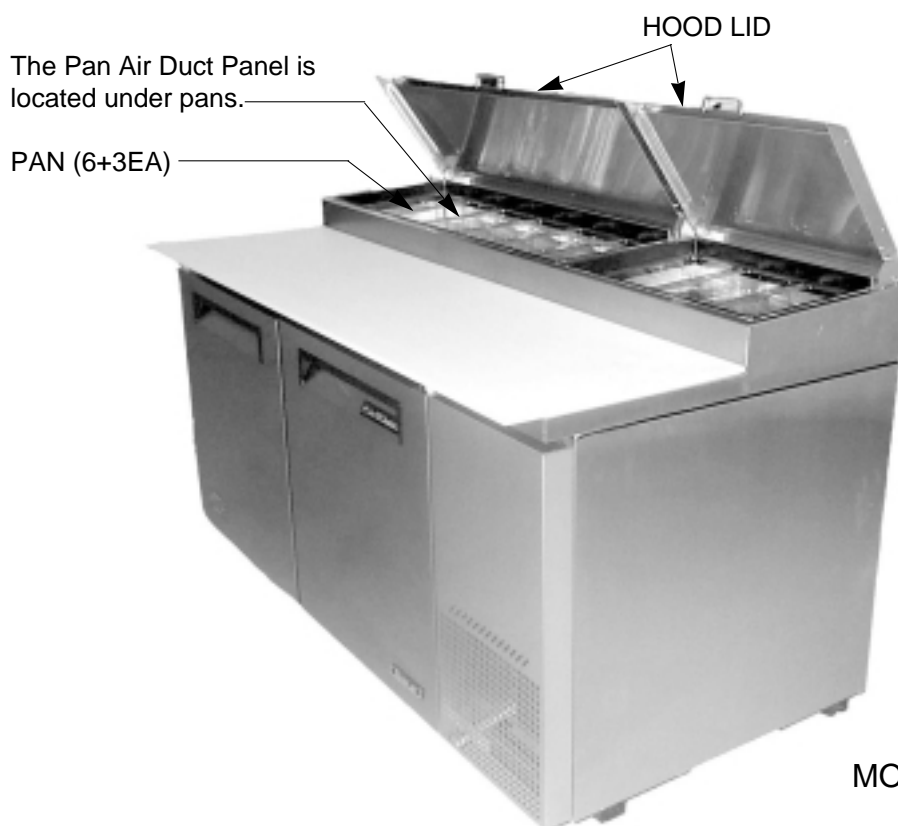

- 1) Remove all pans.
- 2) Clean the PANEL with cloth and warm water.
 - ✳ When cleaning where pans are located or putting and removing food, be careful that hood lid is in lid brackets correctly so it will not fall.

HOW TO OPEN AND CLOSE THE HOOD LID

- 1) When opening HOOD LID, push forward away from you till locked in place at lid bracket.
- 2) When closing HOOD LID, lift handle and pull up, and close slowly.

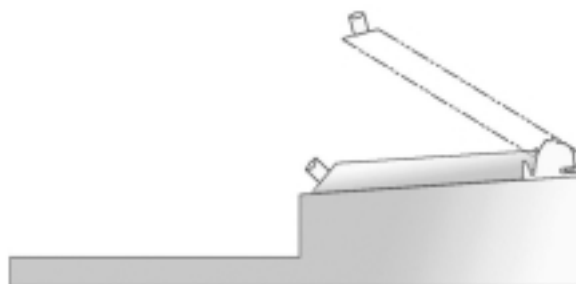

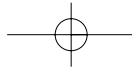

INSTALLATION

1. GOOD AIR CIRCULATION

- Do not place any object that will restrict air flow in front or back grills.
- Turbo air highly recommends that there is ample space in rear of unit. 3 inches or more is best.

2. PLACE ON STRONG GROUND

- Be sure the location chosen has a floor strong enough to support the total weight of the cabinet and contents.

3. DO NOT PLACE NEAR HEAT

- Be sure to avoid hot corners and locations near stoves.
- High ambient temperature will make cooling efficiency lower.

4. INDOOR USAGE ONLY

- Be sure to install this unit indoor, so it will not get wet from the rain.

5. STABILIZING

- Make sure the unit is installed in a stable condition with the front wheels locked while in use.

6. LEVELING

- Be sure that the unit is level from front to back and side to side.

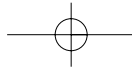

CLEANING

Before cleaning, turn unit off at power switch.

1. CLEANING THE INTERIOR AND EXTERIOR

- The interior and exterior of the unit can be cleaned using warm water with soap.
- Do not use an abrasive cleaner because it will scratch the surface.

2. CLEANING THE CONDENSER FINS

- To maintain proper refrigeration performance, the Condenser coil must be free of dust, dirt, and grease.

This will require periodic cleaning. Condenser fins should be cleaned at least every three months (90 days) or as needed.

- To clean condenser, unplug at power cord. Condenser can be cleaned with vacuum, brush, or CO₂ (high pressure air).

3. CLEAN THE GASKET

- The door gasket should be cleaned frequently to maintain proper sealing.

4. CLEAN THE DRAIN PAN

- Empty the Drain Pan which is located under the unit, periodically.
- When reinstalling Drain Pan, make sure Drain Hose is placed back in pan.

5. CHECK AFTER CLEANING

- Plug unit back in and turn on power switch.
- Check that the unit is operating properly.

CAUTION

1. POWER CORD

- Be sure the power cord is connected to the proper voltage.
- A protected circuit of the correct voltage and amperage must be run for connection of the line cord.
- Turn 'off' the power switch before disconnecting the power cord, whenever performing maintenance functions or cleaning the refrigerated cabinet.
- Compressor warranties are void if compressor burns out due to low voltage.

2. RE-STARTING

- If disconnected, wait 5 minutes before re-starting.

3. POSITIONING FOOD

- Do not obstruct the air inlet which is located at the right inside of the unit.
- Check the gap between the air inlet and food (etc.) whether above 3 inch or not.

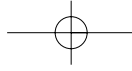

BASIC OPERATION

PPT-67

REFRIGERATORS

1. The controller(thermostat) is located at the right inside of the unit.
2. The factory setting for the control is 'Normal', and maintains about 38°F (3°C) inside.
3. Set toward "Cool" for higher temperature and "Cold" for lower temperature.

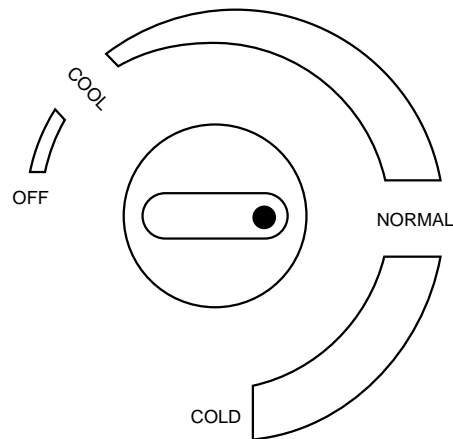

**Temperature Controller
(Thermostat)**

4. The thermostat controls compressor's cycling by sensing inside temperature.
5. When unit will not be used for a long time, turn the power switch off located under the thermostat knob.

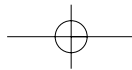

BEFORE REQUESTING SERVICE

SYMPTOMS	CAUSES	SOLUTIONS
Refrigerator(Freezer) is freezing(melting) food.	<ul style="list-style-type: none"> • The setting temperature is too low(high) to maintain food freshness. 	<ul style="list-style-type: none"> • Turn the temperature dial to a warmer(colder) setting.
The unit does not refrigerate at all.	<ul style="list-style-type: none"> • There is a power connection failure problem. 	<ul style="list-style-type: none"> • Check the power cord to make sure the unit is plugged in it correctly.
The unit does not refrigerate well.	<ul style="list-style-type: none"> • The unit is in sunlight or near a heating device. • The unit contains hot food or too much food. • The unit door is opened too frequently or left open too long. • The temp. dial is not on the correct position. • The condenser is clogged. 	<ul style="list-style-type: none"> • Move out of sunlight or away from heater. • Check the condition of stored food. • Check the position of the temp control dial.
There is a loud noise.	<ul style="list-style-type: none"> • The floor is too weak or the leveling feet are set incorrectly. • The backside of the unit is too close to the wall. • The tray is not in the correct position. 	<ul style="list-style-type: none"> • Check the installation and adjust the tray position.
There are dew-drops on the unit exterior.	<ul style="list-style-type: none"> • High-moisture air can produce dewdrops during rainy seasons. 	<ul style="list-style-type: none"> • Wipe with a dry cloth.
There are dew-drops on the unit interior.	<ul style="list-style-type: none"> • The door is opened too frequently or left open too long. • Damp food is stored. 	<ul style="list-style-type: none"> • Keep the door closed to remove dewdrops.
The door does not close tightly.	<ul style="list-style-type: none"> • The door is bent. • The unit is not level. • The door gasket has come out. 	<ul style="list-style-type: none"> • Level the unit again. • Reposition the gasket.

The following points are not malfunctions:

- A water-flowing sound can be heard when the compressor stops. This is the sound of REFRIGERANT flowing.
- The compressor does not run during the defrost cycle.

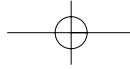

Warranty

Warranty Claims

All claims for labor or parts must be made directly through Turbo Air. If unit was manufactured more than one year, proof of purchase must be faxed in or sent with claim. All claims should include: model number of the unit, the serial number of the cabinet, and all pertinent information supporting the existence of the alleged defect.

If compressor is replaced under warranty, Turbo Air will either request the compressor or compressor tag be returned. Compressor or tag must be returned with all information related to the unit. Any action or breach of these warranty provisions must be commenced within one year after said cause of action has occurred.

One Year Parts & Labor Warranty

Turbo Air warrants to the original purchaser of every new Turbo Air refrigerated unit, the cabinet and all parts thereof, to be free from defects in material or workmanship, under normal and proper use and maintenance service as specified by Turbo Air and upon proper installation and start-up in accordance with the instruction packet supplied with each Turbo Air unit. Turbo Air's obligation under this warranty is limited to a period of one (1) year from the date of original installation or 15 months after shipment date from Turbo Air, whichever occurs first.

Any parts, covered under this warranty, that are determined by Turbo Air to have been defective within one (1) year of original installation or fifteen (15) months after shipment date from manufacturer, whichever occurs first, is limited to the repair or replacement, including labor charges, of defective parts or assemblies. The labor warranty shall include standard straight time labor charges only and reasonable travel time, as determined by Turbo Air.

Additional Four Year Compressor Warranty

In addition to the one (1) year warranty stated above, Turbo Air warrants its hermetically sealed compressor to be free from defects in both material and workmanship under normal and proper use and maintenance service for a period of four (4) additional years from the date of original installation, but not to exceed five (5) years and three (3) months after shipment from the manufacturer.

Compressor determined by Turbo Air to have been defective within this extended period will, at Turbo Air's option, be either repaired or replaced with a compressor or compressor parts of similar design and capacity.

The four (4) year extended compressor warranty applies only to hermetically sealed parts of the compressor and does not apply to any other parts or components, including, but not limited to, cabinet, paint finish, temperature control, refrigerant, metering device, driers, motor starting equipment, fan assembly or and other electrical component, etcetera.

404A / 134A Compressor Warranty

The four-year compressor warranty detailed above will be voided if the following procedure is not carefully adhered to:

1. This system contains R404A or R134A refrigerant and polyolester lubricant. The polyol ester lubricant has rapid moisture absorbing qualities.
2. Drier replacement is very important and must be changed when a system is opened for servicing. A 620 copper drier or better is highly recommended.
3. Micron level vacuums must be achieved to insure low moisture levels in the system. 500 microns or lower must be obtained.
4. When compressor is grounded, suction filter drier and 620 drier or better must be replaced.
5. Compressor must be obtained through Turbo Air Inc., unless otherwise specified in writing, through Turbo Air's warranty department.

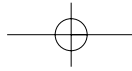

What Is Not Covered By This Warranty

Turbo Air's sole obligation under this warranty is limited to either repair or replacement of parts, subject to the additional limitations below. This warranty neither assumes nor authorizes any person to assume obligations other than those expressly covered by this warranty.

NO CONSEQUENTIAL DAMAGES. TURBO AIR IS NOT RESPONSIBLE FOR ECONOMIC LOSS; PROFIT LOSS; OR SPECIAL, INDIRECT, OR CONSEQUENTIAL DAMAGES, INCLUDING WITHOUT LIMITATION, LOSSES, OR DAMAGES ARISING FROM FOOD OR PRODUCT SPOILAGE CLAIMS WHETHER OR NOT BECAUSE OF REFRIGERATION FAILURE.

WARRANTY IS NOT TRANSFERABLE. This warranty is not assignable and applies only in favor of the original purchaser / user to whom delivered. ANY SUCH ASSIGNMENT OR TRANSFER SHALL VOID THE WARRANTIES HEREIN MADE AND SHALL VOID ALL WARRANTIES, EXPRESS OR IMPLIED, INCLUDING ANY WARRANTY OF MERCHANTABILITY OR FITNESS FOR A PARTICULAR PURPOSE.

IMPROPER USAGE. TURBO AIR ASSUMES NO LIABILITY FOR PARTS OR LABOR COVERAGE FOR COMPONENT FAILURE OR OTHER DAMAGES RESULTING FROM IMPROPER USAGE OR INSTALLATION OR FAILURE TO CLEAN AND / OR MAINTAIN PRODUCT AS SET FORTH IN THE WARRANTY PACKET PROVIDED WITH THE UNIT.

ALTERATION, NEGLIGENCE, ABUSE, MISUSE, ACCIDENT, DAMAGE DURING TRANSIT OR INSTALLATION, FIRE, FLOOD, ACTS OF GOD. Turbo Air is not responsible for the repair or replacement of any parts that Turbo Air determines have been subjected after the date of manufacture to alteration, neglect, abuse, misuse, accident, damage during transit or installation, fire, flood, or act of God.

IMPROPER ELECTRICAL CONNECTIONS. TURBO AIR IS NOT RESPONSIBLE FOR THE REPAIR OR REPLACEMENT OF FAILED OR DAMAGED COMPONENTS RESULTING FROM ELECTRICAL POWER FAILURE, THE USE OF EXTENSION CORDS, LOW VOLTAGE, OR VOLTAGE DROPS TO THE UNIT.

NO IMPLIED WARRANTY OF MERCHANTABILITY OR FITNESS FOR A PARTICULAR PURPOSE: THERE ARE NO OTHER WARRANTIES, EXPRESSED, IMPLIED OR STATUTORY, EXCEPT THE ONE (1) YEAR PARTS & LABOR WARRANTY AND THE ADDITIONAL FOUR (4) YEAR COMPRESSOR WARRANTY AS DESCRIBED ABOVE. THESE WARRANTIES ARE EXCLUSIVE AND IN LIEU OF ALL OTHER WARRANTIES, INCLUDING IMPLIED WARRANTY AND MERCHANTABILITY OR FITNESS FOR A PARTICULAR PURPOSE. THERE ARE NO WARRANTIES, WHICH EXTEND BEYOND THE DESCRIPTION ON THE FACE HEREOF.

OUTSIDE U.S. AND CANADA: This warranty does not apply to, and Turbo Air is not responsible for, any warranty claims made on products sold or used outside the United State and Canada.

CHANGES MADE TO WARRANTY COMMENCED ON 5/1/2002



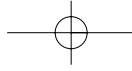

MB MASTER-BILT®
Refrigeration Solutions

908 Highway 15 North • New Albany, MS 38652

Phone: (662)534-9061 • Toll-Free: 800-647-1284

FAX: (662)534-6049 • Toll-Free: 800-232-3966

www.master-bilt.com

