

MB MASTER-BILT® *Refrigeration Solutions*



MD/MDT-04,06,08

Installation & Operations Manual

Master-Bilt Products
908 Highway 15 North
New Albany, MS 38652
Phone: (800) 684-8988

PN 063-90000
Rev 1-28-10 LN

TABLE OF CONTENTS

	<u>Page Numbers</u>
INTRODUCTION	4
WARNING LABELS AND SAFETY INSTRUCTIONS	5
PRE-INSTALLATION INSTRUCTIONS	6
Specation for ShippingDamage.....	6
INSTALLATION INSTRUCTIONS	6
Store Conditions.....	6
Location.....	7
Leveling.....	7
Joining Sections.....	8
Installing Joining Trim MD.....	9
Installing Joining Trim MDT.....	10
Installing the Endsskirts and Kickplate.....	11
Removing and Replacing Bumper Trim.....	11
Removing and Replacing the Ends.....	12
Removing and Replacing the Canopy.....	12
Plumbing.....	13
Electrical.....	13
Piping.....	14
Refrigeration System Evacuating and Charging.....	15
EPR Valve/Temperature Control.....	15
Control Settings.....	15
STARTING PROCEDURE	16
FINAL CHECK LIST	16
LOADING	17
CLEANING	17
NIGHT CURTAINS	17
SERVICE INSTRUCTIONS	18
MASTER-BILT PART NUMBERS	19
SALE AND DISPOSAL	20
WIRING DIAGRAMS	21-23
MD REFRIGERATION SIZING CHART	24

INTRODUCTION

Thank you for purchasing a Master-Bilt cabinet. This manual contains important instructions for installing, using and servicing a Master-Bilt MD series endless open air case. Read all these documents carefully before installing or servicing your equipment. This manual should be left in the care of the store owner or manager.



NOTICE

Read this manual before installing your cabinet. Keep the manual and refer to it before doing any service on the equipment. Failure to do so could result in personal injury or damage to the cabinet.



DANGER

Improper or faulty hook-up of electrical components of the refrigeration units can result in severe injury or death.

All electrical wiring hook-ups must be done in accordance with all applicable local, regional or national standards.



NOTICE

Installation and service of the refrigeration and electrical components of the cabinet must be performed by a refrigeration mechanic and/or a licensed electrician.

The portions of this manual covering refrigeration and electrical components contain technical instructions intended only for persons qualified to perform refrigeration and electrical work.

This manual cannot cover every installation, use or service situation. If you need additional information, call or write us:

Customer Service Department
Master-Bilt Products
Highway 15 North
New Albany, MS 38652
Phone (800) 684-8988
Fax (800) 684-8988

WARNING LABELS AND SAFETY INSTRUCTIONS



This symbol is the safety-alert symbol. When you see this symbol on your cabinet or in this manual, be alert to the potential for personal injury or damage to your equipment.

Be sure you understand all safety messages and always follow recommended precautions and safe operating practices.



NOTICE TO EMPLOYERS

You must make sure that everyone who installs, uses or services your cabinet is thoroughly familiar with all safety information and procedures.

Important safety information is presented in this section and throughout this section and throughout the manual. The following signal words are used in the warnings and safety messages:

DANGER: Severe injury or death will occur if you ignore the message.

WARNING: Severe injury or death can occur if you ignore the message.

CAUTION: Minor injury or damage to your cabinet can occur if you ignore the message.

NOTICE: This is important installation, operation or service information. If you ignore the message, you may damage your cabinet.

The warning and safety labels shown throughout this manual are placed on your Master-Bilt Products cabinet at the factory. Follow all warning label instructions. If any warning or safety labels become lost or damaged, call your customer service department at (601) 534-9061 for replacements.

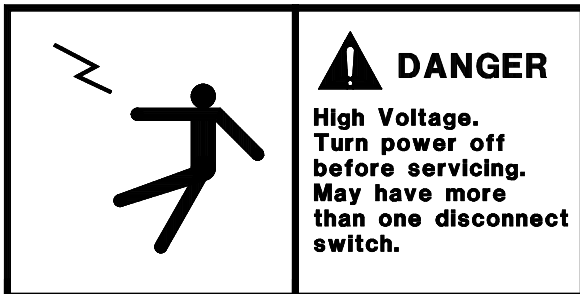

This label is located on top of the electrical control label and on the wiring channel.

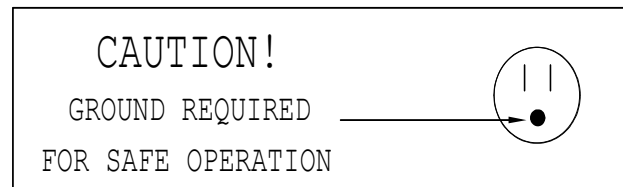

This label is attached to the cabinet power cord on models with a power cord.

PRE-INSTALLATION INSTRUCTIONS

INSPECTION FOR SHIPPING DAMAGE

You are responsible for filing all freight claims with the delivering truck line. Inspect all cartons and crates for damage as soon as they arrive. If damage is noted to shipping crates or cartons or if a shortage is found, note this on the bill of lading (all copies) prior to signing.

If damage is discovered when the cabinet is uncrated, immediately call the delivering truck line and follow up the call with a written report indicating concealed damage to your shipment. Ask for an immediate inspection of your concealed damage item. Crating material must be retained to show the inspector from the truck line.

INSTALLATION INSTRUCTIONS

GENERAL INSTRUCTIONS

1. Be sure the equipment is properly installed by competent service people.
2. Keep the equipment clean and sanitary so it will meet your local sanitation codes.
3. Rotate your stock so that older stock does not accumulate. A "First-In, First-Out" rotation practice will keep the products in good salable condition.
4. Product should not be put in the case for at least 6 hours after it is started.
5. Stock cases as quickly as possible, exposing only small quantities to store temperatures for short periods of time.
6. When replacing burned out fluorescent tubes, be sure that the electrical power to the lighting circuit is turned off.

STORE CONDITIONS

The Master-Bilt MD cases are designed to operate in the controlled environment of an air conditioned store. The store temperature should be at or below 75°F and a relative humidity of 55% or less. At higher temperature or humidity conditions, the performance of these cases may be affected and the capacity diminished. It is not uncommon in a newly constructed store for the temperature and humidity to be above design conditions. These excessive conditions may produce sweating in the case until the store is operational and the ambient environment is more desirable.

The Master-Bilt MD-06/08 should not be positioned where it is directly exposed to rays of the sun or near a direct source of radiant heat or air flow. No HVAC return or supply air ducts may be located near case openings. This will adversely affect the case air flow and will result in poor performance. Do not open windows or doors that will affect the case air flow. The maximum air velocity near the case air return is 50 FPM. If this case is to be located against a wall there should be at least a 6" space between the wall and the back of the case. This space will allow for the circulation of air behind the case which will prevent condensation on the exterior surfaces.

These cases should always be loaded properly. This unit will operate differently when loaded or unloaded. Consult the section of this manual that specifies loading procedures.

A P-trap is included with each case. It is important that each case has a P-trap installed. Consult the section of this manual for installing and piping the drain.

To comply with Sanitation requirements; the cabinet must be mounted on legs (6" high min.) or casters or the base must be sealed to the floor (MDT) with an N.S.F. listed silicone sealant. Minimum clearance allow at least a 4" space between the wall and the back of the case. This space will allow for the circulation of air behind the case which will prevent condensation on the exterior surfaces.

LOCATION

Make sure that the floor will support this equipment is of adequate strength to prohibit sagging. After confirming the dimensions of case, measure off and mark on the floor the exact location of the cases for the entire lineup. Snap chalk lines where the base skids of the case are to be located as shown in **Figure 1**.

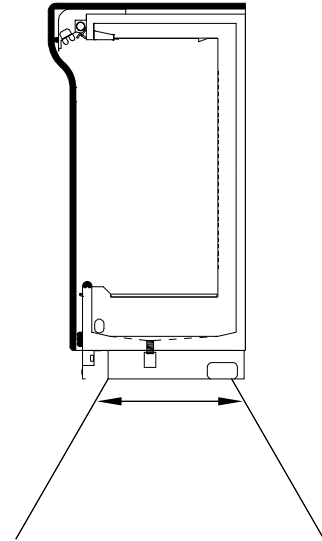
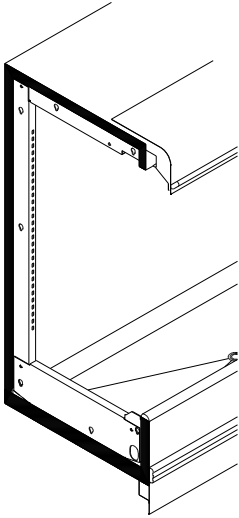

Figure 1

LEVELING

It is very important that this equipment be perfectly level. This will allow for proper and complete drainage of the evaporator coil and for proper case alignment. A perfectly level area is generally not available where the equipment is to be installed. Mark the location of all case joining points front and back. Use a transit to locate the highest point on the chalk lines. This point will be a reference point for determining shim-pack heights. Using the reference point, mark the difference directly on the floor to each joining point front and back. Shim each joining point to equal the reference point as required. Tape all shims in place. If the installation is an entire lineup install the case that will be positioned at the highest point first. Check that the equipment in the lineup is level as the installation proceeds.

JOINING SECTIONS



Remove the case from its shipping skid. Set the first case into its desired position with required shims in preparation for joining it with its adjacent case.

The joining gasket for cases in a lineup is factory installed and is shown in black in **Figure 2**. This gasket is only required on one end of cases in a lineup as only one gasket is needed between two cases. Inspect the gasket to insure that it is properly located and is not damaged. The cases are now ready to be joined together. Remove the second case from its shipping skid and move it into position against the end of the first case. Properly level the second case with the appropriate shims

Figure 2

Bolt the cases together through the seven holes that are provided in the steel end frame as shown in **Figure 3**. Tighten the bolts until all seams are fully closed. Do not over tighten. Repeat the above process for all other cases in the lineup.

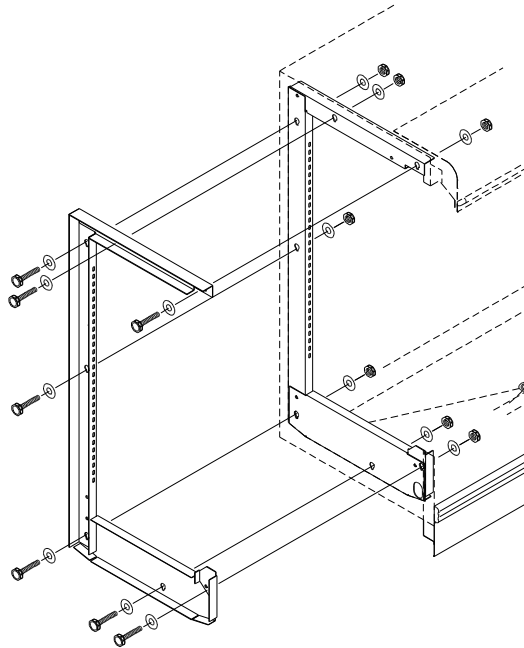
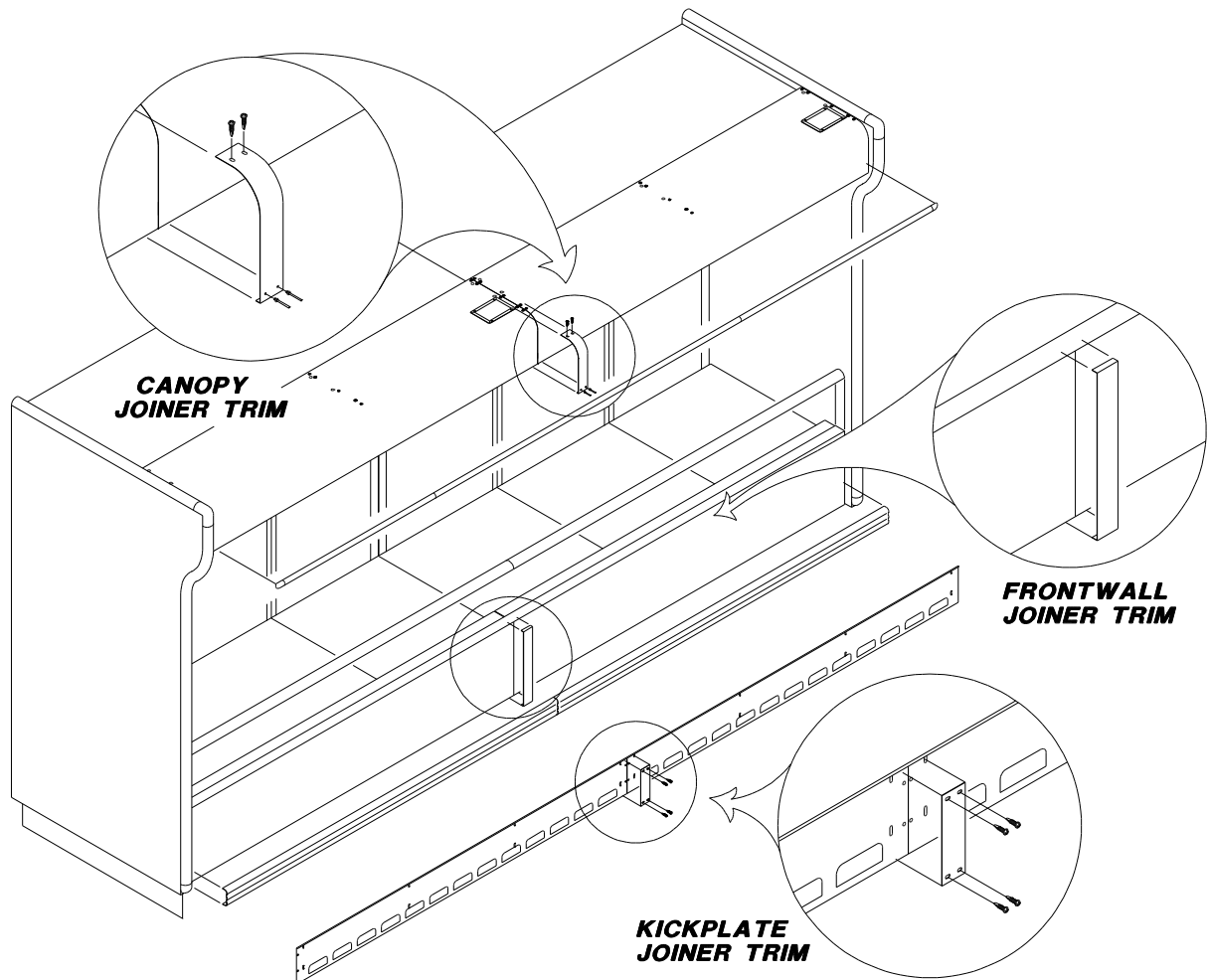

Figure 3

INSTALLING JOINING TRIM, MD

A trim kit for joining sections consists of three pieces: the canopy joiner trim, the frontwall joiner trim, and the kickplate joiner trim. Begin by removing all of the bumper trim and retainers on the canopy and the frontwall. Refer to the section of this manual for removing and replacing bumper trim. The canopy joiner trim is attached by locating the holes in the top of the canopy that will line up with the holes in the canopy joiner trim. Remove the screws that are in the canopy and move the canopy joiner trim into position. Replace the screws that will retain the canopy joiner trim at the top. Now, mark and drill two 1/8" dia. holes in the bottom of the canopy where the bottom holes of the canopy joiner trim will align. Pop rivet the trim into place using 1/8" pop-rivets as shown in **Figure 4**. The frontwall trim will attach to the frontwall using a good two-sided adhesive tape or silicon caulking. The bumper on the top and the front of the frontwall will help to hold this trim in place, but an adhesive is also needed. The kickplate joiner trim will attach to the adjoining kickplates using self-drilling screws as shown in **Figure 4**.

Figure 4



INSTALLING JOINING TRIM, MDT

A trim kit for joining sections consists of three pieces: the canopy joiner trim, the frontwall joiner trim, and the kickplate joiner trim. Begin by removing the bumper trim and retainers on the frontwall. Refer to the section of this manual for removing and replacing bumper trim. The canopy joiner trim is attached by locating the holes in the top of the canopy that will line up with the holes in the canopy joiner trim. Remove the screws that are on the underside of the canopy and move the canopy joiner trim into position. Replace the screws that will retain the canopy joiner trim at the bottom. Use #10 self-drilling screws to secure the canopy joiner trim at the top. The frontwall trim will attach to the frontwall using a good two-sided adhesive tape or silicon caulking. The bumper on the top and the front of the frontwall will help to hold this trim in place, but an adhesive is also needed. The kickplate joiner trim will attach to the adjoining kickplates using sheet metal screws as shown in **Figure 5**.

Figure 5

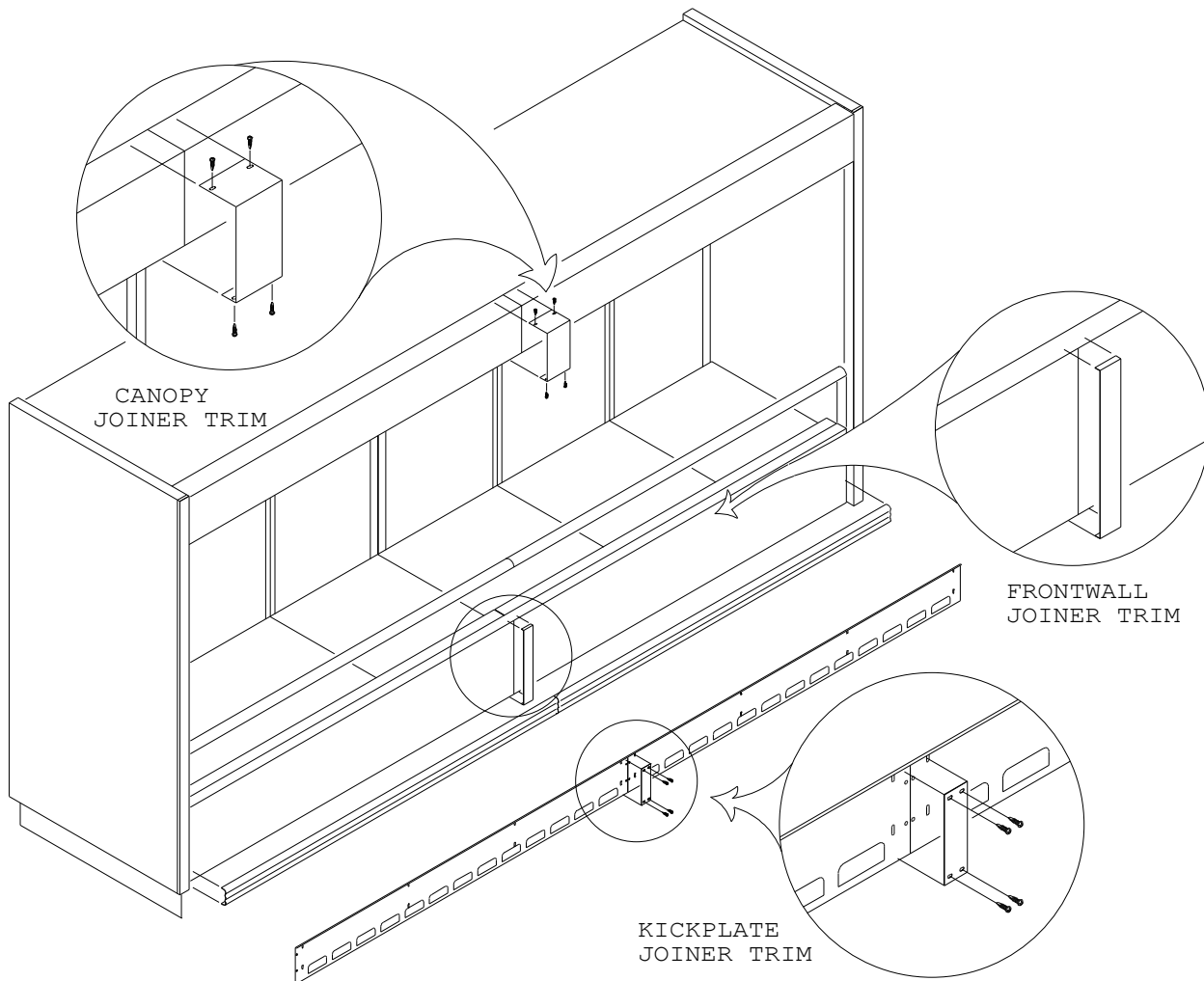

INSTALLING THE ENDSKIRTS AND KICKPLATE

The kickplate should be installed prior to attaching the endskirts. The endskirts are shipped loose. Secure the kickplate to the flange of the wire raceway using the supplied sheet metal screws. Use the supplied sheet metal screws to secure the kickplate to the bottom edge of the frame and the electrical raceway. The bottom of the kickplate should be in contact with the floor. Refer to **Figure 6** for the placement of the Kickplate. The endskirt will attach to the ends of the lineup using the supplied #10x1/2 self drilling screws as shown in **Figure 6**.

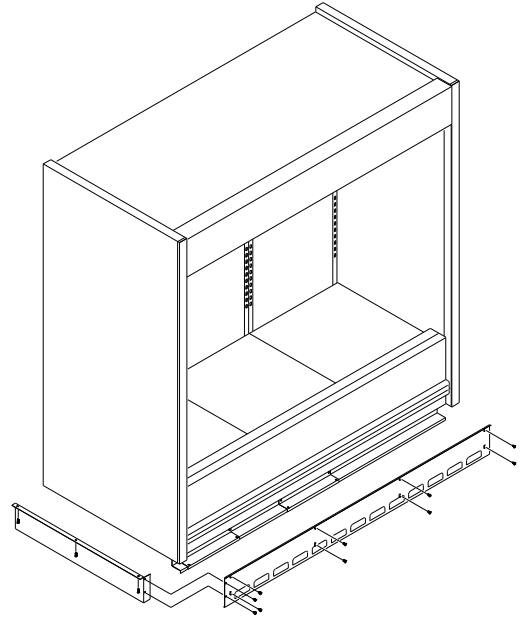
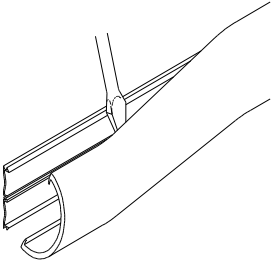

Figure 6

REMOVING AND REPLACING BUMPER TRIM



All of the bumper trim on the MD line is of the same type. To remove a section, begin at one end and unsnap the bumper from the retainer. A screwdriver may have to be used to get the bumper started as shown in **Figure 7**. Use the proper safety precautions when removing the bumper. The endcaps and the bumper retainer can now be removed by removing the screws that attach the pieces to the cabinet. Be sure to use the same type screws to replace the retainer and the endcaps.

Figure 7

REMOVING AND REPLACING THE ENDS

The ends are manufactured so that they will accept a 1/2" bolt. These bolts should not be removed. The ends are bolted to the cabinet as shown in **Figure 8** through a keyslot rather than a hole. To remove an end simply untighten the bolts, lift up on the end and remove the end from the cabinet as shown in **Figure 9**. If you should accidentally remove a bolt, be sure to replace the bolt before attempting to replace the end onto the end frame. When replacing an end make sure that the cabinet is completely sealed but do not overtighten the bolts and remember to inspect the gasket material prior to replacement. Reverse the procedure to replace the ends.

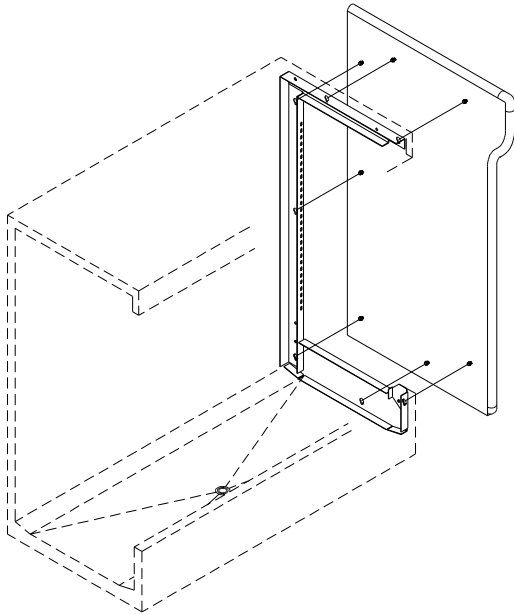

Figure 9

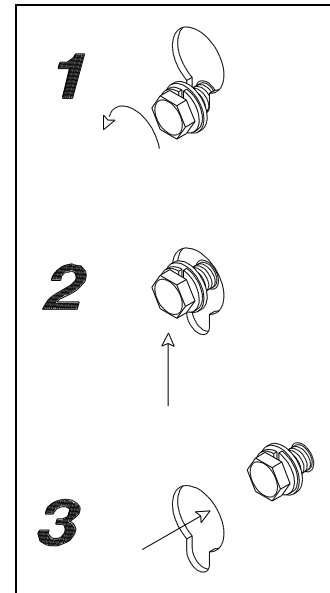

Figure 8

REMOVING AND REPLACING THE CANOPY (MD ONLY)

Before the canopy can be removed, the light bar must be unplugged from the cabinet. There is a light plug access cover on the top of the canopy on the right end as shown in **Figure 10**. Remove this cover using a phillips head screw driver to reveal the light plug and unplug the male end from the female end. Now the canopy can be removed. While carefully supporting the canopy, use a phillips head screwdriver to remove the #10 self-drilling sheet metal screws that attach the canopy to the cabinet as shown in **Figure 11**. Reverse this procedure to replace the canopy making sure that the male plug and the female plug are fully plugged into each other.

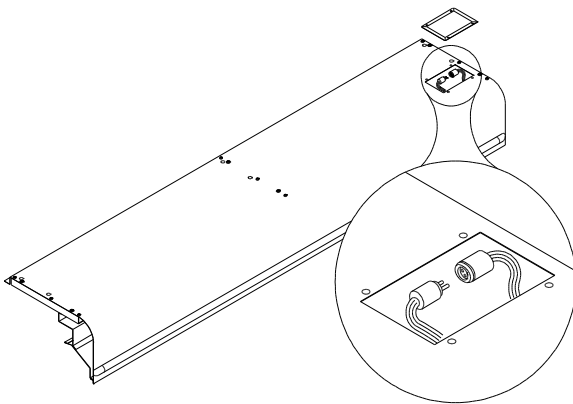

Figure 10

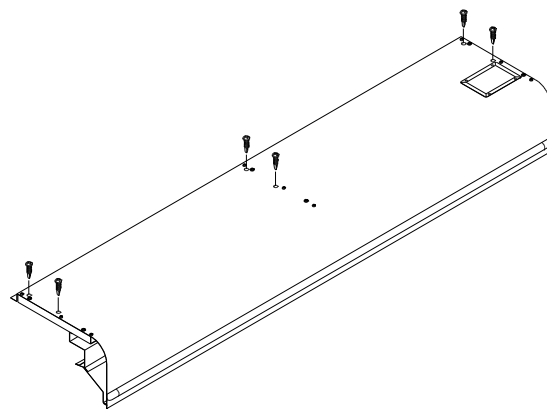

Figure 11

PLUMBING

Each MD case has a P-trap shipped loose. It is very important that this trap be installed as it will result in diminished performance of the case without it. There is a P-trap access cover which can be removed for better admittance to the trap as shown in **Figure 12**. The PVC P-trap assembly must be glued to the PVC adapter on the bottom of the drain. The drain can be run to the front or back or through the skids. The top of the 1-1/2" drain can be accessed by removing the center insulated bottom panel. An access cover can then be removed from the evaporator fan cover. The drain is located at the center of the case in the drain pan.

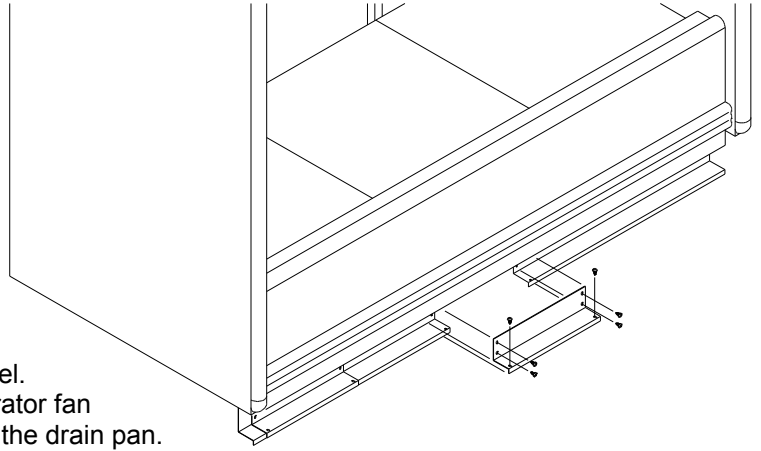

Figure 12

1. Always install drains in accordance with local codes.
2. Use largest possible size pipe for drains, 1-1/2" minimum is recommended.
3. Provide as much downhill slope as possible.
4. Prevent drains from freezing. Do not install drains in contact with uninsulated suction lines.



NOTICE TO STORE OWNERS / MANAGERS

Moisture or liquid around or under the cabinet is a potential slip/fall hazard for persons walking by or working in the general area of the cabinet. Any cabinet malfunction or housekeeping problem that creates a slip/fall hazard around or under the cabinet should be corrected immediately.

If moisture or liquid is observed around or under a Master-Bilt cabinet, an immediate investigation should be made by qualified personnel to determine the source of the moisture or liquid. The investigation made should determine if the cabinet is malfunctioning or if there is a drain pipe leaking.

ELECTRICAL



WARNING

Before servicing electrical components in the case make sure all power to case is off. Always use a qualified technician.



NOTICE

For models with electronic ballast only:



For replacement ballast, use only ballast that complies with UL Type CC rating if unit is equipped with electronic ballast.

It is very important that full voltage and overcurrent protection requirements for condensing units, defrost heaters, fans, doors, etc. be provided at installation. Wire sizing must be adequate to maintain full voltage under amperage loads specified in the charts on page 24. Wiring diagrams are provided for single cabinets and for lineups on pages 22 and 23 of this manual.

PIPING

The recommended type of refrigerant used in the Master-Bilt is R-22. Line sizes for most applications are given in the chart on page 24. Consult the Master-Bilt Refrigeration Unit I&O Manual for other applications. The piping connections are made at the left end of the coil.

These lines have been capped and should be cut with a tubing cutter so as not to introduce copper shavings into the system. Only clean, dry, sealed refrigeration grade AC hard copper tubing should be used. There is a cutout near the front of the case which is used for bringing the lines from underneath the case. It may be easiest to pre-fabricate the lines as shown in **Figure 12** and insert the line up through the bottom of the case. If this is not possible there is an access cover which can be removed for ease of brazing and for service. Be sure to install a suction line oil trap or 'P-trap' as shown in **Figure 13**. The skids are designed with a cutout in the rear of the skid for running refrigeration piping through the skids as shown in **Figure 14**. There is ample room for piping for the MD/MDT and for another cabinet or lineup at the rear of the cabinet.

It is recommended that all brazed joints be made with silver alloy-type solders. For roof top condensing units, an inverted P-trap must be installed in the suction line where the refrigeration lines exit onto the roof. For vertical line runs of more than 20 feet., a riser trap must be installed at the approximate center of the riser. The condensing unit should be located as closely as possible to the cabinet. Keep the refrigeration lines as short as possible and use as few fittings as practicable, being especially careful not to "kink" the lines. Keep the layouts as

simple as possible and properly support the piping to absorb vibration and the normal expansion and contraction caused by temperature changes. All suction lines should be well-insulated to minimize heat absorption and control condensate which could form on the suction line. If tubular insulation is used, the ends, joints, and any other open areas (including slits necessary to fit the tubing over installed piping) should be sealed with insulation glue. A minimum amount of flux should be used as needed and a small amount of dry nitrogen should be fed into the tubing during brazing to minimize formation of scale and oxidation inside the tubing. Leak check all joints with an electronic leak detector or halide torch. If leaks are found relieve the pressure and make repairs as necessary and recheck. Thoroughly caulk or foam all refrigeration line entry holes. All openings for wiring should be sealed with N.S.F. listed sealant to prevent air leaks and unwanted condensation.

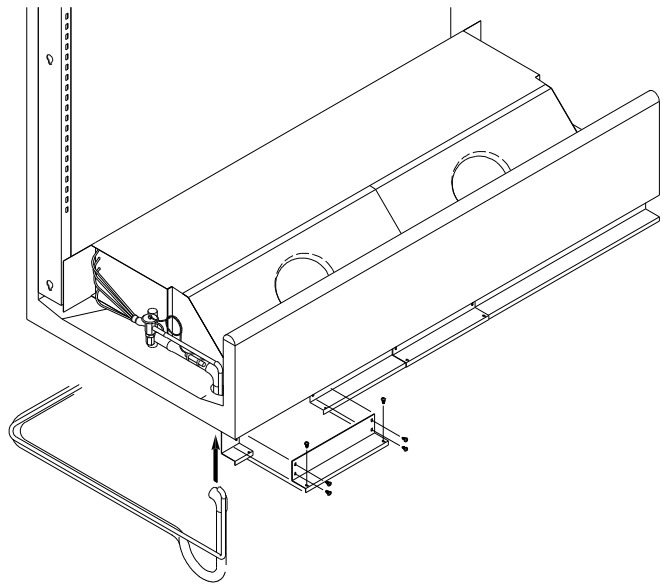

Figure 13

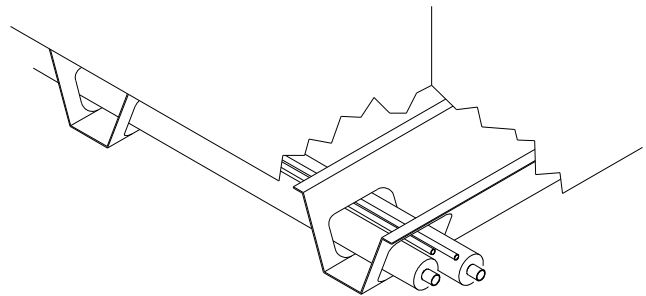

Figure 14

REFRIGERATION SYSTEM EVACUATING AND CHARGING

1. Blow out all refrigerant lines with dry nitrogen or carbon dioxide to eliminate the possibility of dirt, scale, etc. remaining inside.
2. Connect all lines and leak test all connections.
3. Connect a good high vacuum pump to both the low and high side service valves.
4. Operate the pump until a vacuum of 1500 microns (0.06 inches of mercury) absolute pressure is obtained. At this point, the vacuum should be broken by the introduction of refrigerant into the system, through a drier, until the pressure is brought up to zero pounds gauge. Repeat this procedure two more times. During the final evacuation, a vacuum of 500 microns (0.02 inches of mercury) absolute pressure should be obtained. After this vacuum is reached, the system can be fully charged with refrigerant.

EPR VALVE/ TEMPERATURE CONTROL



NOTICE

The evaporator pressure regulator valve (EPR valve) is not used to control temperature in the MD case. This cabinet is equipped with a temperature control which should be properly field wired as a control for the system. Refer to the wiring diagrams on pages 21 to 23 of this manual.

The factory installed temperature control is located at the right end of the evaporator fan cover as shown in Figure 14. This control can be exposed and adjusted by removing the bottom panels at the bottom of the case. It is not necessary to open the evaporator fan cover to access these controls. The sensing bulb for the temperature control is located between the evaporator fan covers and the fan housing in the return air. The temperature control is adjusted by simply turning the knob clockwise for a colder case and counter-clockwise for a warmer case. The temp control should be set so that it cycles off when the discharge air at the honeycomb reaches 24-26°F.

The EPR valve should not be used to control temperature. It is installed to prevent the evaporator pressure from becoming too low in the event of low charge, low temperature control settings, or a failed temperature control. If the EPR valve is not properly installed the evaporator coil could begin to ice. Actual settings will vary from location to location depending on ambient conditions but the EPR valve should be set so that the evaporator pressure will not go below 47-58 lbs for R-404a.

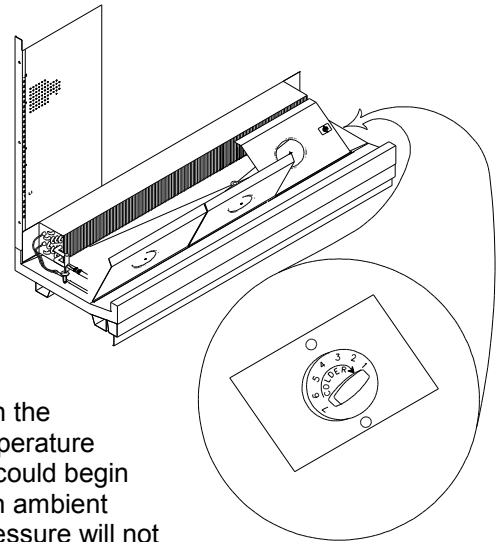

Figure 14

This will insure that the evaporator coil doesn't operate at a temperature too low.

CONTROL SETTINGS

EPR Valve setting	45 - 60 psig
Temperature Control - Air Discharge Temperature	24-26°F at honeycomb
Condensing Unit Defrost Settings	4 times/day (6 hours); 30 minutes fail safe
Condensing Unit Low Pressure Control	Cut in – 20 lbs*: Differential 16 lbs
Condensing Unit High Pressure Control	425 lbs

**This is a standard setting; extreme cold climates may necessitate that the low pressure control be set to a 4 lb cut-out and 20 lb. differential.*

STARTING PROCEDURE

1. Start compressor and allow to run at least 6 hours before placing product into the MD.

DURING THIS TESTING PERIOD YOU SHOULD:

1. Check the temperature holding range against the the control setting.
2. Check the defrost control system to see that all ice is removed from the coil during each defrost cycle.
3. Check pressures.
4. Check EPR Valve for proper pressure.

FINAL CHECK LIST

- A. Check high-low pressure control settings.
- B. Check setting of defrost timer:
 1. Four defrost/24 hours, with 30 minutes fail safe.
- C. Check operating pressure.
- D. Check electrical requirements of unit to power supply voltage.
- E. Set temperature control for desired temperature range. Set at '6' for most applications.
- F. Check setting of thermostatic expansion valve for proper operation. Approx. 10°F superheat.
- G. Check sight glass for proper refrigerant charge.
- H. Check EPR Valve for proper pressure setting.
- I. Check system for proper defrost settings and operation.
- J. Check condensing unit for vibrating or rubbing tubing. Dampen or clamp as required.
- K. All valves should be completely open counter-clockwise.
- L. Check packing nuts on all service valves.
- M. Replace all service valve caps and latch unit covers.
- N. Check refrigeration line for proper P-traps and proper locations.
- O. Check drain for proper P-traps and proper locations.

LOADING

Do not place product in the case until 6 hours after it is started. Stock cases as quickly as possible, exposing only small quantities to store temperatures for short periods of time. It is important to keep stock rotated properly so that older stock does not accumulate. A "First-In, First-Out" rotation practice will keep the products in good sellable condition. Avoid loading the case so that product sticks out beyond the shelves or blocking the return air grille at the bottom of the case. This will interfere with the air flow of the case and will result in diminished performance.

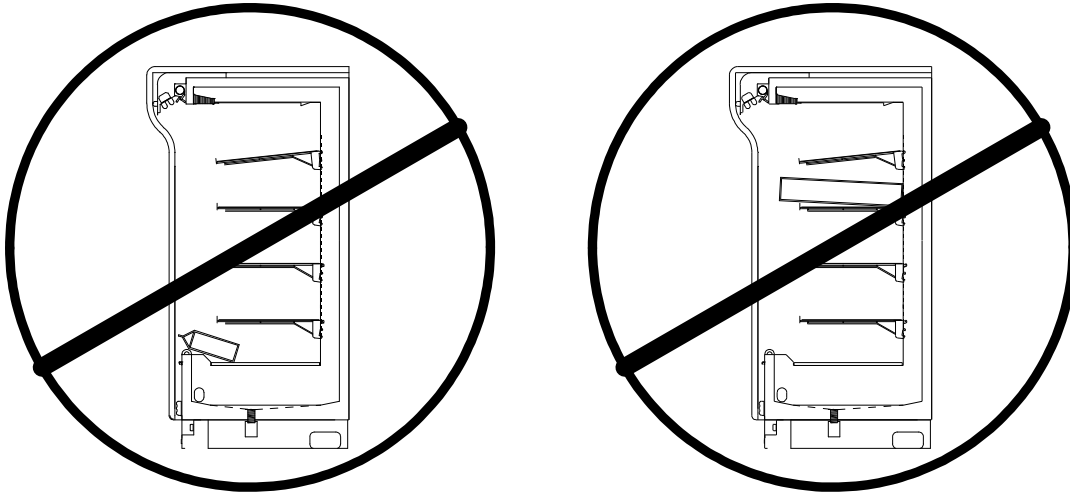

Figure 15

CLEANING



To avoid electrical shock, turn the power off before cleaning.

The MD series cabinets are designed so that spills will accumulate in a drain pan. The drain pan is located underneath the return air grill. Be sure to clean all areas with a mild detergent and water periodically. **DO NOT USE ABRASIVE CLEANERS.**

NIGHT CURTAINS

The MD cases are equipped with a heavy duty night curtain located just behind the the light bulbs. All that is visible is the handle. Using the night curtains properly will conserve a considerable amount of energy. The night curtains should be lowered when the store is closed or the case is not in use. There is a hook mounted on the lower front of the case that the handle of the curtain will catch in. When raising the night curtains, do not unhook the handle and release it as the curtain will spring back into its raised position abruptly possibly damaging the curtain or the case. Instead, unhook the handle and gently guide the curtain back into its raised position. This will extend the looks and the life of the curtain.

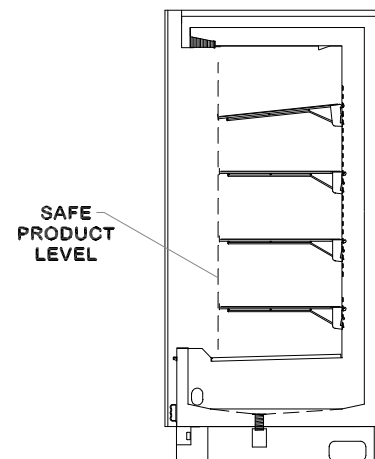

Figure 16

SERVICE INSTRUCTIONS (Trouble Shooting Guide)

1. High head pressure and high back pressure:
 - A. Condenser coil clogged or restricted.
 - B. Condenser fan motor defective.
2. Low head pressure and low back pressure:
 - A. Restriction in system.
 - B. Refrigerant undercharged.
 - C. Leak in system.
 - D. EPR valve set too low.
3. Pressures normal – cabinet warm:
 - A. Coil blocked with frost or ice (**see #4**).
 - B. Control set too warm.
 - C. Air screen disturbance.
4. Coil blocked with frost or ice:
 - A. Defective temperature control.
 - B. EPR valve set too low.
 - C. Time clock not operating properly.
 - D. Improper time clock setting
 - E. Ambient conditions above 75°F and 55%RH
 - F. Defrost heater not operating
 - G. P-trap in drain not installed
 - H. Air screen disturbance
 - J. Evaporator fan motor defective
5. Compressor starts and runs but cycles on overload:
 - A. Low voltage.
 - B. Dropped Phase (3 phase)
 - C. Overload protector defective.
 - D. High head pressure (**see #1**).
 - E. Relay or Capacitor Defective (1 phase)
6. Compressor will not start – hums, but cycles on overload:
 - A. Low voltage.
 - B. Relay defective.
 - C. Overload protector defective.
 - D. Start capacitor defective.
 - E. High head pressure (**see #1**).
7. Special service situations:

If moisture or liquid is observed around or under a Master-Bilt cabinet, an immediate investigation should be made by qualified personnel to determine the source of the moisture or liquid. The investigation made should determine if the cabinet is malfunctioning or if there is a simple housekeeping problem.

Moisture or liquid around or under a cabinet is a potential slip/fall hazard for persons walking by or working in the general area of the cabinet.

Any cabinet malfunction or housekeeping problem that creates a slip/fall hazard around or under a cabinet should be corrected immediately.

MASTER-BILT PART NUMBERS

The table below gives Master-Bilt part numbers. Use this chart when ordering replacement parts for your MD cases.

All quantities are one each unless otherwise noted by parentheses.

Description	MD-04/MDT-04	MD-06/MDT-06	MD-08/MDT-08
Evaporator Coil	07-13230	07-13209	07-13199
Expansion Valve	09-09478	09-09468	09-09468
Defrost Heater	(2) 17-09273	(2) 17-09258	(2) 17-09259
Heater Safety	19-01307	19-01307	19-01307
Temperature Control	19-00844	19-00844	19-00844
Evaporator Fan Motor	(2) 13-13124	(2) 13-13124	(3) 13-13124
Evaporator Fan Blade	(2) 15-13092	(2) 15-13092	(3) 15-13092
Evaporator Fan Guard	(2) 25-00205	(2) 25-00205	(3) 25-00205
Drum Thermometer	19-13586	19-13586	19-13586
Discharge Honeycomb Insert	29-01517	(1.5) 29-01517	(2) 29-01517
Shelf	(8) 33-01533	(12) 33-01533	(16) 33-01533
Standard 24" Flourescent Lamp	N/A	(2/1) 23-01576	N/A
Standard 36" Flourescent Lamp	(2/1) 23-01577	(2/1) 23-01577	(2/1) 23-01577
Standard 48" Flourescent Lamp	N/A	N/A	(2/1) 23-01575
Lamp Shield, 36"	(2/1) 25-01274	(4/2) 25-01274	(2/1) 25-01274
Lamp Shield, 48"	N/A	N/A	(2/1) 25-01311
Ballast	23-01704	(2/1) 23-01704	(2/1) 23-01704
Lampholder	(4/2) 23-50562	(8/4) 23-50562	(8/4) 23-50562
Lamp Switch	23-50793	23-50793	23-50793
Night Curtain, 4'	56-00058	N/A	(2) 56-00058
Night Curtain, 6'	N/A	56-00059	N/A
Curtain Mounting Bracket	(2) 56-00061	(2) 56-00061	(5) 56-00061
Curtain Spindle Holder	56-00060	56-00060	(2) 56-00060
Curtain Hold Down Hook	56-00050	56-00050	(2) 56-00050

SALE AND DISPOSAL

OWNER RESPONSIBILITY

If you sell or give away your Master-Bilt cabinet you must make sure that all safety labels and the Installation - Service Manual are included with it. If you need replacement labels or manuals, Master-Bilt will provide them free. Contact the customer service department at Master-Bilt at (800) 684-8988.

The customer service department at Master-Bilt should be contacted at the time of sale or disposal of your cabinet so records may be kept of its new location.

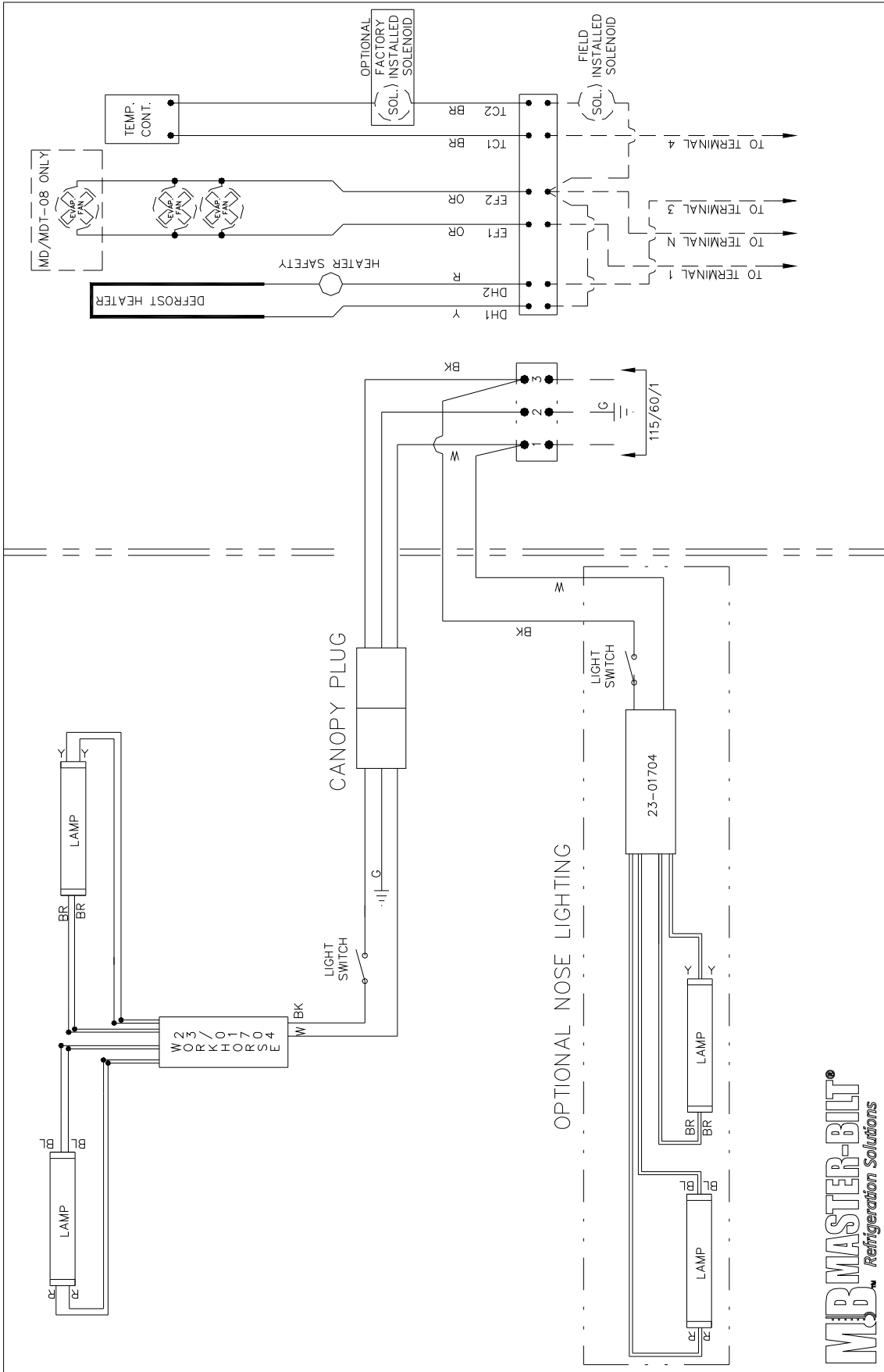

MB MASTER-BILT®
Refrigeration Solutions

CANOPY WIRING — — — FIELD WIRING CABINET WIRING 03/18/10

MD/MDT -06, -08 WIRING DIAGRAM MD-MDT-0608_WH_NOISE LIGHTING_03-18-10

FIELD WIRING DETAIL

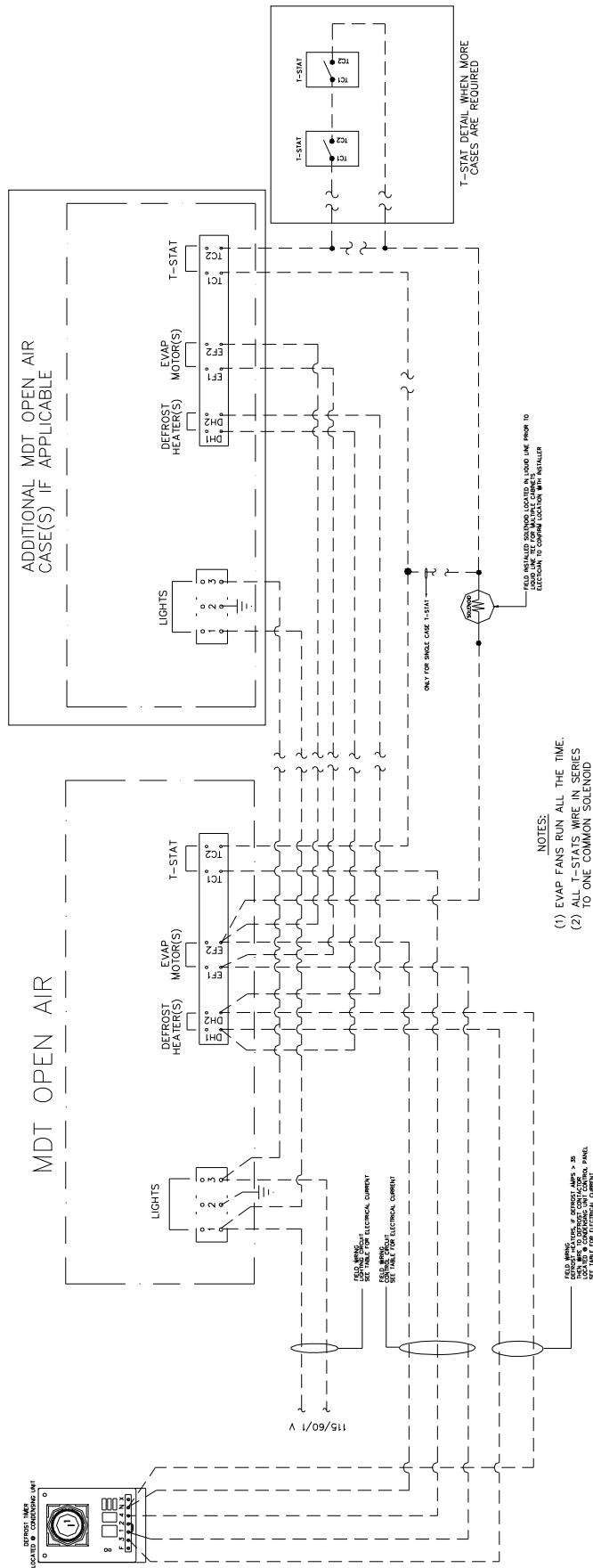

MDT -OX MDT -OX

MD REFRIGERATION SIZING CHART

TOTAL OVERALL LENGTH*	MODELS REQUIRED			R404A	R404A	R404A	R404A
	MDT-04	MDT-06	MDT-08	NORMAL AMBIENT UNIT UP TO 100°F**	+15F Suction, 120F Condensing TO 120°F**	HIGH AMBIENT UNIT 100°F	+15F Suction, 140F Condensing
4'0"	1			MHHZ0171	CS10K6E	MHHZ0221	CS14K6E
6'0"		1		MHHZ0171	CS10K6E	MHHZ0221	CS14K6E
8'0"			1	MHHZ0191	CS12K6E	MHHZ0331	CS20K6E
10'0"	1	1		MHHZ0301	CS18K6E	MHHZ0431	CS27K6E
12'0"		2		MHHZ0331	CS20K6E	MHHZ0431	CS27K6E
14'0"		1	1	MHHZ0431	CS27K6E	MHHZ0501	CS33K6E
16'0"			2	MHHZ0431	CS27K6E	MHHZ0501	CS33K6E
18'0"		3		MHHZ0431	CS27K6E	MSHZ0501	ZB38KCE
20'0"		2	1	MHHZ0501	CS33K6E	MSHZ0501	ZB38KCE
22'0"		1	2	MHHZ0501	CS33K6E	MSHZ0581C	ZB45KCE-TF5
24'0"			3	MSHZ0501	ZB38KCE	MSHZ0581C	ZB45KCE-TF5
26'0"		3	1	MSHZ0501	ZB38KCE	BSHZ0750C	ZB56KCE-TWC
28'0"		2	2	MSHZ0581C	ZB45KCE-TF5	BSHZ0750C	ZB56KCE-TWC
30'0"		1	3	MSHZ0581C	ZB45KCE-TF5	BSHZ0750C	ZB56KCE-TWC