



Master Controller Reverse Cycle Defrost System

Installation & Operations Manual

**An Electronic Microprocessor-Based
Electric Expansion Valve Refrigeration Control System**



IMPORTANT NOTICES

- **Read this manual before installing your Master Controller system. Keep the manual and refer to it before doing any service on the equipment. Failure to do so may result in personal injury or waive warranty of damaged equipment.**
- Modifications to existing equipment are subject to approval by Master-Bilt and must be explicitly written. There are no implied flexibilities designed into this product.
- The following points apply unless overwritten and approved by the Master-Bilt engineering department:
 - Maximum distance of wires between the evaporator and the Master Controller **MUST** not exceed 40 ft.
 - The Master Controller **MUST** be mounted on the neighborhood of the vestibule entrance door for below -40°F extra low temp freezer
 - All sensor wires **MUST** be in separate metal conduit from power wiring and control wiring for below -40°F extra low temp freezer
- Due to continuous product enhancements, Master-Bilt reserves the right to make engineering changes and change specifications for product improvement without notice.

INTRODUCTION	4
WARNING LABELS AND SAFETY INSTRUCTIONS	5
APPLICATIONS.....	5
MASTER CONTROLLER	6
Description	6
Factory-Mounted Parts.....	8
Features.....	9
Sequences of Operation	10
START UP	10
OFF MODE	10
COOL MODE	10
DEFROST MODE.....	11
Scheduled Defrost	11
Demand Defrost.....	11
Manual Defrost	12
COIL DRAIN MODE	12
FAN DELAY MODE.....	12
SAFETY MODE	12
Master/Slave Configuration.....	13
MASTER/SLAVE MODE	13
ALTERNATING MODE.....	14
Definition of On-Board Symbols.....	14
STATUS, DEFAULT AND READING DISPLAY.....	14
ALARM DISPLAY	16
Setting Parameters by On-Board Pushbuttons	16
Temperature Sensors	17
SENSOR SERVICE INSTRUCTIONS	17
Pressure Transducer	18
Charging the Master Controller Refrigeration System.....	19
Technical Notes	20
Electrical Wiring	20
TYPICAL WIRING DIAGRAMS	21
REVERSE CYCLE DEFROST	23
General Information	23
Advantages	23
Factory-Installed Parts	23
Eliminated Parts.....	24
Defrost Time	24
Charging a Master Controller System Equipped with Reverse Cycle Defrost.....	24
Reverse Cycle Defrost Wiring Diagram	25
TYPICAL SET POINTS FOR CONTROLLER	27
TROUBLESHOOTING GUIDE	28
Troubleshooting Electric Expansion Valve	29
MASTER-BILT PART NUMBERS.....	29

INTRODUCTION

Thank you for purchasing a Master-Bilt Master Controller Reverse Cycle Defrost system. This manual contains important instructions for installing, using and servicing the system as well as a parts list. Read this manual carefully before installing or servicing your equipment.



DANGER

Improper or faulty hook-up of electrical components of the refrigeration units can result in severe injury or death.

All electrical wiring hook-ups must be done in accordance with all applicable local, regional or national standards.



NOTICE

Installation and service of the refrigeration and electrical components must be performed by a refrigeration mechanic and/or a licensed electrician.

The portions of this manual covering refrigeration and electrical components contain technical instructions intended only for persons qualified to perform refrigeration and electrical work.

This manual cannot cover every installation, use or service situation. If you need additional information, call or write us:

Customer Service Department
Master-Bilt Products
Highway 15 North
New Albany, MS 38652
Phone: 800-684-8988
Fax: 866-882-7629
Email: service@master-bilt.com

WARNING LABELS AND SAFETY INSTRUCTIONS



This is the safety-alert symbol. When you see this symbol, be alert to the potential for personal injury or damage to your equipment. Be sure you understand all safety messages and always follow recommended precautions and safe operating practices.



NOTICE TO EMPLOYERS

You must make sure that everyone who installs, uses or services your refrigeration is thoroughly familiar with all safety information and procedures.

Important safety information is presented in this section and throughout the manual. The following signal words are used in the warnings and safety messages:

DANGER: Severe injury or death will occur if you ignore the message.

WARNING: Severe injury or death can occur if you ignore the message.

CAUTION: Minor injury or damage to your refrigeration system can occur if you ignore the message.

NOTICE: This is important installation, operation or service information. If you ignore the message, you may damage your refrigeration system.

The warning and safety labels shown throughout this manual are placed on your Master-Bilt refrigeration system at the factory. Follow all warning label instructions. If any warning or safety labels become lost or damaged, call our customer service department at 800-684-8988 for replacements.

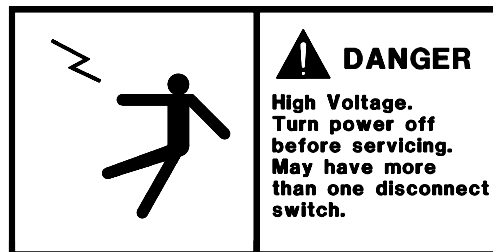

This label is on the housing of the Master Controller typically located on an evaporator coil.

APPLICATIONS

Master Controller Reverse Cycle Defrost systems are designed to control Master-Bilt made condensing units and evaporators for freezer and cooler applications. Each system contains a condensing unit, evaporator(s) with Master Controller board(s), electric expansion valve(s), pressure transducers, temperature sensors, reverse cycle valve and operational controls.

MASTER CONTROLLER

Description

The Master Controller is a custom-designed microprocessor-based electronic controller for Master-Bilt refrigeration products to control an electric expansion valve in response to evaporator superheat and return air temperature. The hardware and input/output descriptions and connections of a Master controller are shown below.

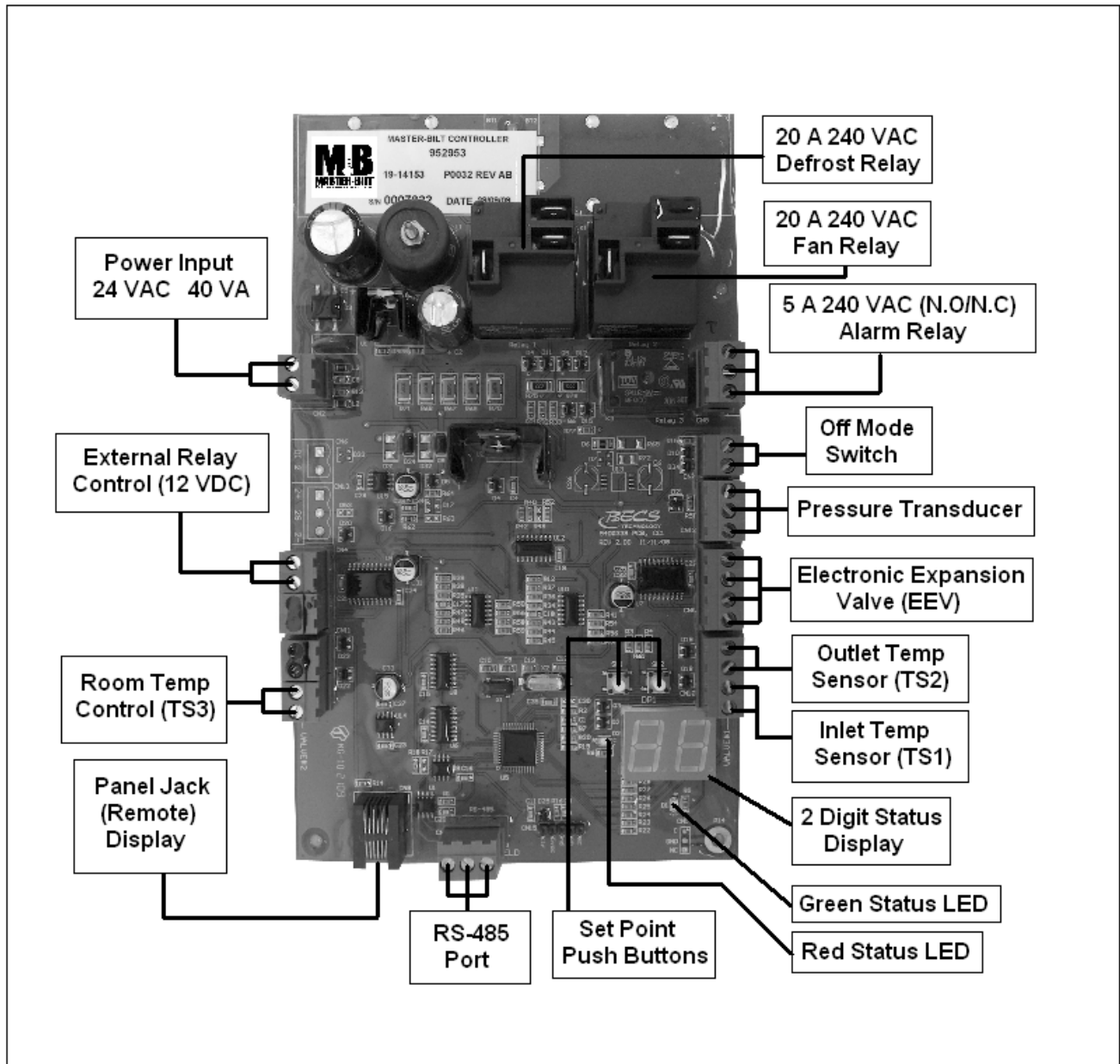

Figure 1 . Master Controller Board Layout.

- **SEI or SER Terminals.** Sporlan SEI and SER type electric expansion valves are currently used for all applications. There are 1596 nominal steps for entire valve stroke.
- **Off Mode Switch** is a digital input 'DI1'(J7). Shorting of pins tells controller to shut everything off for 45 minutes. The defrost heaters, evaporator fans, and output to control the relay for the solenoid valve or the compressor are turned off. The valve is also shut. An open between the pins of 'DI1' tells the controller to run in normal operation. This can be a stocking timer switch.
- **Pressure Transducer** is mounted at the evaporator suction header to measure saturated suction pressure in absolute value but displayed in gauge pressure in PSIG. The suction pressure is converted to evaporating temperature. The difference between outlet temperature and evaporating temperature is the true superheat displayed as "SH".
- **Defrost Termination Temperature Sensor TS1** is mounted downstream of the distributor tube after the valve and close enough to the evaporator coil to measure defrost termination temperature during defrost cycle. Figure 2 on the previous page shows the sensor locations of the evaporator and the controller.
- **Outlet/Fan Cut-In Temperature Sensor TS2** is mounted on the suction line about 6" to 10" away from the evaporator to measure outlet temperature during cooling cycle and to serve as evaporator fan cut-in temperature sensor. The sensor is at a 2 or 10 o'clock position on the suction line. The default value of the fan cut-in temperature is pre-set at 20°F for commercial refrigeration application.
- **Room Temperature Sensor TS3** is typically mounted with a plastic tie at the drain pan on the side of the evaporator return air. It is located around the middle of the evaporator to allow even air flow across it. If necessary, it can be relocated to a spot with better representation of the cold room temperature.
- **Two Digit LED Display** is used to show status of the controller, set point values and temperatures.
- **Green and Red LED Status Indicators.** When power is applied to the controller, the green LED will be on constantly during normal operation. The red LED is the negative sign for temperatures showing less than 0°F on the two digit LED display. If the red LED is off, the two digit display reading is between 0 to 99°F. If it is on, the 2 digit display reading is between -60 to -1°F. A blinking red LED indicates an alarm occurrence.
- **Two Push Buttons** are used to display set points and status as well as to reset operational parameters like room temperature, defrost mode, number of defrosts, etc. Their functions can be also performed by an optional remote display panel.
- **Two 20 Amp, 240 VAC NC/NO Relays.** Relay 'K1' is used for the defrost heater when the heater load is less than 20 amp. It will be wired to defrost heater contactor when heater load is over 20 amp or three phase heaters. **For a reverse cycle defrost system, it is wired to a 40VA transformer that provides 24VAC power to the reversing valve solenoid coil.** Relay 'K2' is used to switch evaporator fans ON and OFF. A fan contactor will be used if the fan motor is larger than 20 amps or three phase or the voltage is different from control voltage.
- **One 5 Amp, 240 VAC NC/NO Relay** is an option for an external alarm system. The customer can decide what type of a physical alarm is used. This relay is energized when the controller is powered on. Whenever the controller gives an alarm, the relay will be de-energized. For example, a technician can connect a phone alarm system to this relay. When there is an alarm, the alarm system can dial in his pager or cellular phone.
- **Panel Display Jack.** When a remote display panel is used for a standalone Master Controller system, this jack is used to connect the remote panel display with a communication cable supplied by the factory. The remote display will not work when RS-485 serial port is in use for a Master/Slave system or network communications.
- **One RS-485 Serial Port** is used for Master/Slave system or an alternating system communication requiring two-wire connection. When the wires are longer than 20 feet, a shielded two-wire cable should be used. The shield end should be connected to the master board only.
- **Power Input 24 VAC 40 VA**

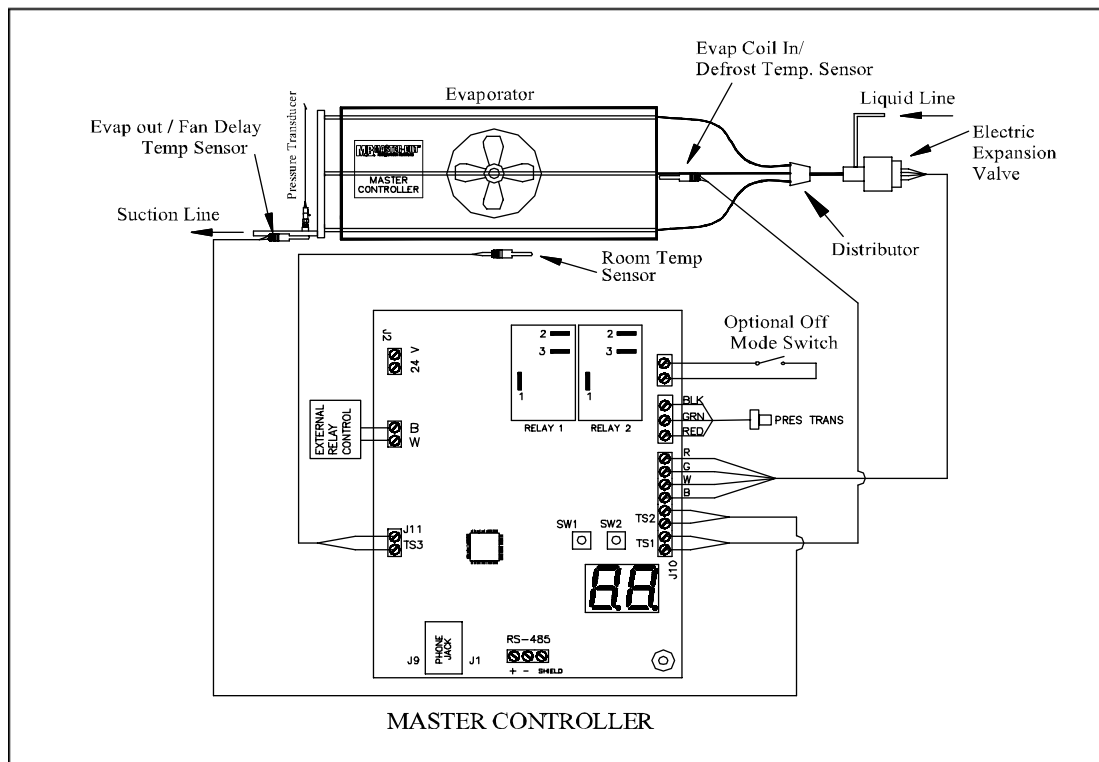

Figure 2.

Factory-Mounted Parts

- A controller board, an electric expansion valve, a pressure transducer, three temperature sensors and a 24 VAC 40VA transformer for single evaporator system (standalone or alternating) or master (multiple evaporator system) evaporator are pre-mounted at the factory. For a multiple evaporator system, the Slave evaporator has two temperature sensors. For reverse cycle defrost, another 24 VAC 40VA transformer is mounted at standalone or master evaporator to provide power 24VAC to the four-way reversing valve mounted in the condensing unit. The control circuit and power supply are pre-wired to the terminal board of the evaporator. The board is conformal coated and the transformer is plastic coated to avoid excessive moisture in cold room.
- An external relay, which controls a liquid solenoid valve, is mounted on board (in the evaporator) with an **electric defrost system**. It is mounted in the condensing unit on a **reverse cycle defrost system (see p. 23)** to control compressor contactor. A 4-way reversing valve, operating at 24 VAC, is installed in a reverse cycle defrost equipped unit. A transformer is also installed in the Master evaporator to supply 24VAC to the 4-way reversing valve. The external control relay has a 12VDC coil and is wired at B and W terminals on the left side of the controller board as illustrated in Figure 2.
- Master and Slaves are connected through the RS-485 port in a Master/Slave system. The Master and Slave controllers are designed identically. Addresses must be set for each controller. The communication cables for RS-485 connections and remote panel display is supplied by the factory. A technician should install the cable between RS-485 terminals of the Master and Slaves and set the addresses correctly in field. The cable for RS-485 connections is a three-wire 18 to 24 AWG rated 300V cable. **The remote panel display is used for single evaporator system only.**
- All components are factory tested. A technician should check all the wiring and settings for proper operation after installation.

Features

- One of the most energy-saving features of the Master Controller Reverse Cycle Defrost system is free floating head pressure. A head pressure control is not installed on Master Controller systems. Without this control, compressors work at the highest efficiency at the lowest possible condensing pressure rather than at the limited pressure level typically found in conventional systems using a head pressure control valve for low ambient environments. For more energy saving information, go to www.master-bilt.com/pdfs/master_controller_vs_standard_system.pdf.
- The electric expansion valve replaces a thermal expansion valve. The refrigerant flow of the electric expansion valve is modulated by the true superheat, or the difference of evaporator outlet and evaporating temperatures.
- The room temperature sensor replaces the conventional temperature control. The temperature is set with the two pushbuttons on the Master Controller board. The default temperature must be checked during the first startup of the machine against actual application temperature. Default must be re-set to actual application temperature if there is a discrepancy.
- The on-board timer is used for run time control and scheduling defrosts. No mechanical defrost timer is necessary for this system. Once the power is turned on, the timer starts counting.
- The Master Controller has the capability to perform scheduled defrost or demand defrost
 - When the scheduled defrost scheme is chosen, the on-board timer is used for scheduled defrosts. The system works in the same fashion as a regular conventional system with mechanical defrost timer.
 - When the demand defrost is chosen, the controller will not initiate a defrost unless it is needed. The low temperature system is pre-set with demand defrost.
- The demand defrost scheme is a pioneer design by Master-Bilt for freezer applications. Extensive lab tests indicate that many unnecessary defrosts are eliminated and energy consumption reduced when using demand defrost compared to using a conventional refrigeration system equipped with a mechanical defrost timer.
- The operational status of modes, room temperature and alarms is displayed on the two-digit on-board display.
- Manual defrost is available on standalone and Master/Slave systems.
- All components are factory-mounted, pre-wired and tested to save on-site installation labor and reduce chance of installation errors.
- The superheat set point has a wide adjustability range 5° to 20 °F. This range allows the controller to meet different customers' needs, and require less refrigerant charge for winter operation than conventional refrigeration unit when no head pressure valve is installed in the condensing unit.
- The controller can be used in low, medium and high temperature applications. The internal programming will recognize the input of room temperature set point (**rS** or **RMSP**) and automatically select appropriate segments of the program for the application.
- The patented reverse cycle defrost control (**United States Patent 7,073,344**) reduces defrost energy usage by up to 80% and decreases defrost time from 20-45 minutes (freezer equipped with electric heaters) to 3-5 minutes in a freezer or 1¹/₂ – 2 minutes in a cooler with a completely clean defrost.
- Maximum operating suction pressure can be controlled by the electric expansion valve eliminating the crankcase pressure regulator for some applications.
- Minimum operating suction pressure provides additional compressor protection.
- The off mode switch turns off the evaporator fans during loading or unloading of refrigerated items.

Sequences of Operation

START UP

When power is applied to the board, the controller closes the valve. The controller will display 'Su' on its two-digit display for five seconds. It will then display 'CF' on the two-digit display for 10 seconds. The evaporator fans will be on for the first 15 seconds allowing a service technician time to check them. The controller will then turn the fans off and check each sensor. The controller will check the pressure transducer for a short or open. It will display 'CP' on the two-digit display for three seconds. If the sensor fails, the controller will display an alarm and go to safety mode for a failed sensor. If the sensor passes, it will display 'oP' on the two-digit display for three seconds. The controller will check the sensor connected to 'TS1' for a short or an open. It will display 'C1' on the two-digit display for three seconds. If the sensor fails, the controller will display the alarm 'Si' on the two-digit display and go to safety mode for a failed inlet sensor. If the sensor passes, it will display 'o1' on the two-digit display for three seconds. The controller will check the sensor connected to 'TS2' for a short or an open. It will display 'C2' on the two-digit display for three seconds. If the sensor fails, the controller will display the alarm 'So' on the two-digit display and go to safety mode for a failed outlet sensor. If the sensor passes, it will display 'o2' on the two-digit display for three seconds. The controller will check the sensor connected to 'TS3' for a short or an open. It will display 'C3' on the two-digit display for three seconds. If the sensor fails, it will display the alarm 'SA' on the two-digit display and go to safety mode for a failed room temperature sensor. If the sensor passes, it will display 'o3' on the two-digit display for three seconds. If all sensors pass, the controller will display 'FH' on the two-digit display for six seconds. When sensor fails, the alarm relay will be de-energized.

The controller will not go into defrost during the preceding start up procedure. It will check the number of defrosts per day (nd) and time_of_day (TIME). If it is time for the controller to be in defrost, it will start in DEFROST mode. If not, the controller will start in COOL(CL) mode after fan delay.

The set points are stored in EEPROM (Electrically Erasable Programmable Read Only Memory). Batteries are not required to store the new set points. If 24 VAC power is lost, the set points which were in the controller at that time will be used when power is restored.

OFF MODE (oF)

The controller starts in OFF mode by fully closing the valve. The controller will keep the valve closed for the minimum OFF Time (oC) in order to keep the compressor in pumpdown or off for a minimum amount of time. When the room temperature reaches the cut-in set point (room temperature set point "rS" plus the temperature difference set point "rP"), the controller goes to COOL mode (CL).

If a scheduled defrost scheme is selected, while the controller is in OFF mode, it is constantly checking the number of defrosts per day and the time_of_day and calculating the time for defrost. When the time_of_day is right for a defrost, it will immediately go into DEFROST mode right after the current OFF mode.

If the demand defrost scheme is selected, defrost will be checked and initiated only during the COOL mode.

After the Minimum OFF Time is timed out and the room temperature reaches the Cut-In temperature, the controller will go into COOL mode (CL).

While in OFF MODE, the two-digit display on Master will show 'oF' for three seconds, 'ro' for two seconds, and the numerical display of the room temperature for five seconds. The two-digit display on slaves will show 'oF'.

COOL MODE (CL)

The controller starts COOL mode by opening the valve. The condensing unit will start by a suction line low pressure control cut-in. The electric expansion valve is modulated by the controller so that a preprogrammed superheat set point is maintained during the refrigeration process. Actual superheat is the temperature difference of the evaporator outlet and the evaporating temperature converted from the reading of the pressure transducer, or $T_{out} - T_{sat}$. The controller will keep modulating the valve so the superheat will equal the superheat set point. Meanwhile, the controller reads also the room air temperature TS3. When the room temperature is below the room temperature set point (pre-set to -10 °F for low temp), it goes back to OFF mode. All the time that the controller is in COOL mode, it is constantly checking the criteria to determine if a defrost should be initiated. It will immediately go into DEFROST mode (dF) when defrost criteria are met.

If the suction pressure is above the maximum operating pressure set point (MPSP), the valve will modulate to control the pressure at or below the maximum operating pressure set point (MPSP). When the operating suction pressure is lower than MPSP, it will go back to superheat control. Suction pressure is used to calculate saturated temperature (TSAT).

If the suction pressure is below the Minimum pressure set point (NPSP), the valve will close and the control signal to the external relay will be turned off. It will resume normal operation when the pressure is above the Minimum pressure set point.

While in COOL MODE, the two-digit display on Master will show 'CL' for three seconds, 'ro' for two seconds, and the numerical display of the room temperature for five seconds. The two-digit display on slaves will show 'CL'.

DEFROST MODE (dF)

There are two methods to determine if a defrost will be initiated for the Master Controller: scheduled defrost and demand defrost. If the number of defrosts per day 'nd' is set to 0, the controller will do the demand defrost by default. If the number of defrosts per day 'nd' is set from 1 to 12, the controller will do the scheduled defrost.

Scheduled Defrost

The following is the description of the scheduled defrost.

The time_of_day is really an elapsed counter that counts the number of minutes that have passed. An elapsed count of 0 is 12:00 AM. The count goes up to 1439 which corresponds to 11:59 PM. The counter then will reset to 0.

The time of day will be kept as long as the 24 VAC power is connected. If the 24 VAC is turned off, then back on, the time of day will be reset to 0 which corresponds to 12:00 AM.

The first defrost start time is an elapsed time of 0 (12:00 AM). The subsequent defrost start times are determined by adding the number of minutes between each defrost to the previous start time until there is a defrost start time for each defrost per day. The number of minutes between each defrost is determined by taking 1440 / number of defrosts per day as set up by the 'NUMBER OF DEFROSTS' set point.

When starting an electric defrost, K2 relay is energized to turn off the fans. The controller waits for five seconds, then the K1 relay is energized to start a defrost.

When starting a reverse cycle defrost, the K2 relay is energized to turn off the fans while, at the same time, terminals B and W of the controller are de-energized to turn off the compressor. There is a 10 second delay before the K1 relay is energized to switch the four-way reverse valve. Then there is a 30 second waiting period for pressure equalizing. Afterward, terminals B and W are energized to turn the compressor on. Hot gas will be reversed to flow to the evaporator while the electric expansion valve is modulated to start a defrost.

The controllers use the inlet sensor 'TS1' as the defrost termination sensor. When this temperature gets above the preprogrammed 'DEFROST TERMINATION TEMPERATURE SET POINT' before the preprogrammed 'MAXIMUM DEFROST TIME', the defrost will terminate. Otherwise, it will be terminated when the 'MAXIMUM DEFROST TIME' times out.

While in DEFROST MODE, the two-digit display will be 'dF' for three seconds, 'dn' for three seconds, and the numerical display of the temperature reading from sensor TS1 for three seconds.

Demand Defrost

When 'nd' is set to '0', the controller will initiate a demand defrost. The controller will not go to 'DEFROST MODE' until a heavy frost accumulation in the evaporator coil. When frost is built up in the evaporator, it will block the air flowing through the evaporator coil and reduce the heat transfer area. It will also decrease the evaporating temperature, which, in turn, increases probability of frosting. A demand defrost scheme to detect the frost build-up and the criteria to start defrost are programmed in the Master Controller. Unlike scheduled defrost, the Master Controller with demand defrost is really an energy saver. If no selection is made, the controller will automatically select demand defrost when the power is applied to the controller. The defrost procedure is the same as described for the scheduled defrost.

After selecting the demand defrost, if the elapsed time since the last defrost has been a selectable hour (Hb) such as 8, 12, 24, 48 or 72, the Master Controller will go into defrost to ensure a proper oil return.

Manual Defrost

The controller allows manually-initiated defrost when needed. The manual defrost will be disabled if the evaporator inlet sensor detects the temperature higher than the defrost termination temperature. Operation of the manual defrost will be discussed in a later section.

COIL DRAIN MODE (Cd)

The controller automatically goes into COIL DRAIN whenever a defrost is terminated. The controller stays in this mode for the preprogrammed 'DRIP TIME'. When this time is completed the controller opens the expansion valve and goes into FAN DELAY mode (Fd).

While in COIL DRAIN MODE, the two-digit display on the controller will show 'Cd' for five seconds, 'ro' for three seconds, and the numerical display of the room temperature for three seconds. The two-digit display on the slave will show 'Cd'.

FAN DELAY MODE (Fd)

The controller will pull down the temperature of the evaporator without the fans on until one of the following occurs: The FAN DELAY TIME of five minutes times out or the fan cut-in sensor's temperature (FDTP) TS2 goes below the FAN DELAY TEMPERATURE of 30°F. The controller will then go into COOL mode.

While in FAN DELAY MODE, the two-digit display will be 'Fd' for three seconds, 'Fp' for three seconds, and the numerical display of the temperature reading from sensor TS2 for three seconds.

SAFETY MODE

When an alarm occurs, such as a sensor failure or a communication alarm, the controller will go into 'SAFETY MODE'. SAFETY MODE provides minimum refrigeration to the refrigerated room before the corrective action is taken and the alarm is cleared. The system will do the following in Safety Mode:

- Pressure transducer alarm (SP)
 - Cool mode
 - Valve open for the minimum compressor run time
 - Valve closed for the minimum compressor off time
 - Keep doing above cycle until alarm goes away
 - Ignores maximum pressure control mode
- Outlet sensor alarm (So)
 - Cool mode
 - Valve open for the minimum compressor run time
 - Close valve for the minimum compressor off time
 - Keep doing above cycle until alarm goes away.
 - Fan delay mode
 - Lets fan delay time out (five minutes)
 - Defrost Mode
 - If this alarm and defrost term temp sensor alarm, reverse cycle defrost will last only three minutes with valve open;
 - If this alarm and defrost term temp sensor alarm, electric defrost will last only ten minutes with valve closed.
- Box temp sensor alarm (SA)
 - Cool Mode
 - Run on superheat control for the minimum compressor run time
 - Close valve for the minimum compressor off time
 - Keep doing above cycle until alarm goes away.
- Low superheat alarm (LS)
 - Close valve and wait for alarm to go away.
- High Room Temperature Alarm (rH)

The 'high room temperature alarm' occurs when the room temperature is above the preprogrammed 'HIGH TEMPERATURE ALARM' for a preprogrammed number of minutes. The alarm is cleared when the room temperature is less than the 'HIGH TEMPERATURE ALARM' set point.

- Low Room Temperature Alarm (rL)
The 'low room temperature alarm' occurs when the room temperature is below the preprogrammed 'LOW TEMPERATURE ALARM' for a preprogrammed number of minutes. The alarm is cleared when the room temperature is above the 'LOW TEMPERATURE ALARM' set point.
- Defrost term temp sensor alarm (Sd)
 - Defrost mode
 - Open valve until alarm goes away or defrost terminates.
 - If this alarm and outlet temp sensor alarm, defrost will last only three minutes.
 - Use outlet sensor for defrost temperature termination
- Communication alarm (CA)
 - For 'RVC2' go to standalone mode.
 - For 'ELEC' and 'RVC1'
 - Cool mode
 - Run on superheat control for the minimum compressor run time
 - Close valve for the minimum compressor off time
 - Keep doing above cycle until alarm goes away.
 - Pumpdown Mode
 - Wait until pump down time times out.
 - Drip Mode
 - Wait until Drip time times out.
 - Defrost Mode
 - Valve will close when defrost termination temperature meets its set point if reverse cycle defrost. Valve will close at all time if electric defrost. It will then wait the full defrost time for other evaporators to defrost..
 - If in demand defrost mode, defaults to three defrosts per day.

Master/Slave Configuration

The Master Controller can be configured as one Master plus up to five Slaves. Each controller will be appointed one address for communication and sequence of operation. The evaporators are piped together to one condensing unit. The room temperature sensor is mounted at the master evaporator. All evaporators have a pressure transducer, outlet sensor and defrost termination sensor. The master will broadcast commands and status to all slaves. Slaves will acknowledge the reception of the commands and report the status to the master. The master and each slave controller will modulate its electric expansion valve independently .

- The communication wire size can be 18 to 24 AWG, up to 1,000 ft.
- Communication for master/slave control are connected to the terminal labeled 'RS-485' (J1).
- Terminal labeled '+' on master must be connected to terminal labeled '+' on all slaves
- Terminal labeled '-' on master must be connected to terminal labeled '-' on all slaves
- Terminal labeled 'SHIELD' on master must be connected to terminal labeled 'SHIELD' on all slaves

MASTER/SLAVE MODE

When power is turned on, that controller will initialize itself by closing the valve. A 'ROOM TEMPERATURE' sensor is only connected to the master controller. If a controller is configured as a slave, it will not give a 'ROOM TEMPERATURE ALARM'. If it is a 'slave', it will put itself in 'COOL' mode and wait for a command from the 'master'. If it does not receive any command within a minute, it will set the 'communication alarm' and then run in 'SAFETY MODE' as described previously. The 'communication alarm' clears when it receives any command from the 'master'. There are five commands that the 'slave' can receive from the 'master':

- A command for the controller to go to 'OFF' mode,
- One for the controller to go to 'COOL' mode.
- One for the controller to go to 'PUMPDOWN' mode.
- One for the controller to go to 'DEFROST' mode.
- One for the controller to go to 'COIL DRAIN' mode.

If there is a communication alarm at a master or a slave, then the controller will go into defrost as a scheduled defrost that will terminate on time only.

ALTERNATING MODE

The controller can be configured as an alternating system for dual single-evaporator refrigeration units to provide redundancy of a refrigerated cold room. Two communication wires are connected through RS-485 terminals between each evaporator controller. When the alternating mode is selected(**Cn = nL, SL**), the dual refrigeration units will start pulling down box temperature to the cut-out set point then both go into OFF MODE(oF). When the box temperature rises up to cut-in temperature, the unit set up as primary controller(**Cn=nL**) will come on while the other, set as secondary controller(**Cn=SL**), stays off. The secondary evaporator will perform the refrigeration in next cooling cycle.

IMPORTANT NOTE:

In the controller, the parameter of “Er” has to be set for proper method of defrost. “Er = EL” is for regular electric defrost; “Er = r1” is for regular reverse cycle defrost; “Er = r2” is for two redundant systems.

Definition of On-Board Symbols

STATUS, DEFAULT AND READING DISPLAY

When the on-board green light is on, the controller is in normal operation. When the green light is blinking, a set point is being displayed or ready for change. When the red light is blinking, there is an alarm.

The status and the digital data are displayed on the onboard two-digit LED display. Below is a list of the parameters of the operational status.

Onboard Two-Digit Display	Optional Panel Display	Description
SU	STUP	Indicates the status of Start Up Mode
CF	CKFN	Check fan working status
CP	CKP1	Check pressure transducer
oP	OKP1	Indicates the pressure transducer is working as it should
C1	CKT1	Check sensor TS1, the inlet/defrost termination temperature sensor
o1	OKT1	Indicates the TS1 is working as it should
C2	CKT2	Check sensor TS2, the outlet/fan cut-in temperature sensor
o2	OKT2	Indicates the TS2 is working
C3	CKT3	Check sensor TS3, the room temperature sensor
o3	OKT3	Indicates the TS3 is working
FH	CKFH	Indicates all sensors are OK
Fd	FNDL	Indicates FAN DELAY MODE
FP	FDTP	Actual TS2 value in FAN DELAY
CL	COOL	Indicates COOL MODE
oF	OFF	Indicates OFF MODE
Pd	PMDN	Indicates PUMPDOWN MODE before an electric defrost
dF	DEFR	Indicates DEFROST MODE
Cd	DRIP	Indicates COIL DRAIN MODE
dn	DFTP	Inlet sensor TS1 value in DEFROST MODE

A list of the parameters that can be displayed and/or changed is shown below when access to the default settings is needed. This access is usually done by a trained technician.

The Following display are for viewing the status of the refrigeration system and cannot be changed

Control Board Output	Remote Display Output	
ro	RMTP	Refrigerated Room Temperature from TS3 (-40°F to 99°F) Displayed Value
Eo	POSN	Percentage the EEV is open (0-99% on board), number of step on remote display
SH	SUPH	Actual Superheat in COOL MODE (Tout - T _{sat})
in	TSAT	Saturated Suction Temperature calculated from Suction Pressure Pr
oU	TOUT	Evaporator Suction Outlet Temperature Sensor (TS2)
dE	DFTP	Temperature read from the evaporator defrost termination sensor (TS1)
Pr	PRES	Suction Pressure read from the pressure transducer (-14 psi to 99 psig)

The Following list indicates parameter values of the controller and may be changed to customize the refrigeration system

Control Board Output	Remote Display Output	
Cn	CMMD	Addressing for Control Board, indicated system set up (i.e., Standalone, Master/Slave, or Alternating Mode.
Ao	ALON	Indicates system is set up for a Standalone Configuration (1 Condenser matched to 1 evap)
n1-5	MSS1-5	Designates the Master Evaporator. (1-5 depicts the number of slaves connected to the master)
S1-5	SLV1-5	Designates the Slave(s) Evaporator(s). (1-5 depicts the address of the respective slave)
nL	MSAL	Designates the Primary Evaporator in an alternating configuration (2 condensers with 2 evaps)
SL	SLAL	Designates the Secondary Evaporator in an alternating configuration
nS	MSGP	Indicates the address group for a master/slave group or alternating duo (nS = 0 to 7)
SS	SHSP	Superheat Set Point seen at the evaporator (5°F to 20°F)
rS	RMSP	Room Temperature Set Point or "cut-out" (-40°F to 75°F range)
dU	DFTM	Maximum Defrost Duration (10 to 99 minutes, 5 min increments)
dS	DFSP	Defrost Termination Temperature (40°F to 90°F, 5°F increments)
PU	PDTM	Pump Down Timeout duration (0-5 minutes). Only applicable to elec. and air defrost schemes
dr	DRTM	Drip Time Duration (0-10 minutes, 1 minute increments)
nd	NMDF	Number of Defrost/Day. When nd=0, demand defrost, when nd = 1-12, scheduled defrost
HA	HIAL	High Temperature Alarm Set Point (-35°F to 60°F, 5°F increments)
Ad	ALDL	Temperature Alarm Delay (10 to 59 minutes, 1 min. increments)
LA	LOAL	Low Temperature Alarm Set Point (-40°F to 55°F, 1°F increments)
oC	OFTM	Minimum Time the EEV is closed, or minimum off time (0 to 15 minutes)
rn	RNTM	Minimum Time the EEV is open, or minimum run time (0 to 15 minutes)
rP	RNTP	Cut-in Temperature Differential (0°F to 25°F, 1°F increments)
PS	MPSP	Maximum Suction Pressure Set Point (-5.0 psi to 99.0 psig)
Pn	NPSP	Minimum Suction Pressure Set Point (-14.6 psi to 3.0 psig)
Hb	8HR,12HR,24HR 48HR,72HR	Only applicable when in the demand defrost scheme and rS <=35°F, this Set Point designates the time between a safety defrost. (Example; if Hb = 8, then a defrost will occur every 8 hrs.
Ar	LGAD	Addressing of controller(s) for remote logging (Ar=0 to 31)
Er	DFMD	Defrost Type (If Er = EL, then air or electric, If Er = r1 or r2, then reverse cycle defrost)
rr	REFR	Refrigerant Type (If rr = 4A, then R-404A refrigerant, If rr = 22, then R-22 refrigerant)
AL	DIF2	If in alternating mode, this value indicates the number of degrees above the cut-in Set Point (cut-out + rP) at which both controllers are overridden and both go into COOL MODE.

ALARM DISPLAY

Any alarm will cause relay #3 to switch. All alarms have a distinct display shown on the two-digit display on the controller. The green LED will be on and the red LED will blink. Multiple alarms can exist. There is a priority as to which alarm will be displayed before another.

Onboard 2 Digit Display	Optional Panel Display	Description	PRIORITY
	NOAL	Displays when there are no alarms. The onboard 2 digit display will display status and temperature readings	
SP	PRSR	pressure transducer	1
So	SCSR	evaporator outlet temperature sensor TS2 alarm	2
SA	RMSR	room temperature sensor TS3 alarm	3
LS	LOSH	low superheat alarm	4
rH	HIRM	high room temperature alarm	5
rL	LORM	low room temperature alarm	6
Sd	INSR	defrost termination sensor TS1 alarm	7
LP	LPAL	Low pressure alarm	8
CA	CMAL	communication alarm	9

Setting Parameters By On-Board Pushbuttons

When the two-digit display is displaying a temperature or status, the green LED is always on. The red LED is the negative sign. When the red LED is on, it indicates the temperature is below zero. When the green light is blinking, a set point is being displayed or ready for change. When the red light is blinking; it indicates an alarm.

There are two levels for programming the controllers with the two-digit display and two pushbuttons. The first level (User's Level) will enable the USER to set the room temperature set point 'rS'; the second level (Technician's Level) allows access to the other parameters as described above.

User's Level Press and hold 'PB2' until the display shows 'rS' (about five seconds). The green LED will start blinking. The display will toggle between 'rS' and the numerical value of the room temperature set point. The red LED will be off if the set point is positive or on if the set point is negative. Press 'PB1' to increase the room temperature set point by 1°F. Press 'PB2' to decrease the room temperature set point by 1°F. The set point can be changed between -40 °F to +80 °F. If no button is pushed for 20 seconds, the controller will go back to normal operation. The green LED will be on constantly and the mode will be displayed as described above.

TECHNICIAN's Level To enter the second level of programming (able to see all temperatures and change all Set points), press and hold 'PB1' and 'PB2' simultaneously until the display shows 'ro' (about five seconds). The green LED will start blinking. The display will toggle between 'ro' and the numerical value of the room temperature. The red LED will be off if the set point is positive or on if the set point is negative. To scroll down the parameters without changing them, press 'PB2'. To increase the set point by one increment, press 'PB1'. When that set point gets to its maximum value, pressing 'PB1' will rotate it to its minimum value.

CLEAR ALARM Pressing 'PB1' three times within five seconds will cause the controller to clear "LS", "Rh" and "rL" alarms and restart timer.

MANUAL DEFROST If the controller is in OFF or COOL MODE, pressing and holding pushbutton PB1 for over five seconds will cause the controller to go into defrost cycle. If the controller is in PUMP DOWN MODE, pressing and holding pushbutton PB1 for over five seconds will cause the controller to go into DEFROST MODE. If the controller is in DEFROST MODE, pressing and holding pushbutton PB1 for over five seconds will cause the controller to go into COIL DRAIN MODE. If the controller is in COIL DRAIN MODE, pressing and holding pushbutton PB1 for over five seconds will cause the controller to go into FAN DELAY MODE. If the controller is in FAN DELAY MODE, pressing and holding pushbutton PB1 for over five seconds will cause the controller to go into COOL MODE. Manual defrost should be initiated on master only.

Temperature Sensors

The application range of the temperature sensors used for this controller is -50°F to $+103^{\circ}\text{F}$. If the sensor detects a temperature out of the range, an alarm will show on the controller display.

Three temperature sensors are used in the Master Controller refrigeration system. They are the room temperature return air sensor, the evaporator defrost termination temperature surface sensor and the evaporator outlet (suction line) temperature surface sensor. All sensors are solid state devices with the same characteristics that change electrical resistance in response to a change in temperature.

The room temperature sensor is factory-mounted on the lower back of the evaporator at the drain pan. This placement avoids heat from defrost heaters and lights and still allows a good air stream over the sensor. Figure 3 shows a typical mounting of the room temperature sensor.

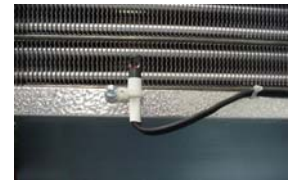

Figure 3

The defrost termination sensor is mounted on one of the distributor tubes close the coil end plate. The outlet sensor is mounted on the suction line at the outlet of the evaporator as shown in Figure 4. These sensors are interchangeable.

SENSOR SERVICE INSTRUCTIONS

Care must be taken when brazing the suction line at the evaporator. The outlet sensor must be taken out before brazing. After brazing, fasten the sensor with the metal strap provided. Make sure the sensor is tight and has good contact with the suction line.

The temperature sensor cannot be repaired. Using the measurements in Chart A below, you can determine if they are functioning correctly. If the sensors are found out of tolerance, they should be replaced.

As mentioned above, the temperature sensor changes electrical resistance in response to temperature changes. Disconnect the sensor from the controller, check the temperature at the sensor location, then check and record the resistance through the temperature sensor.

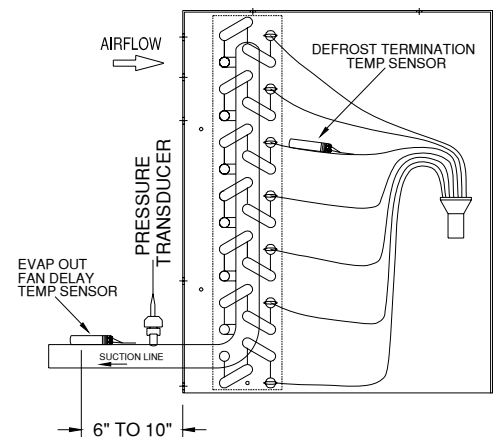

Figure 4

Procedures to check temperature sensor tolerance with ice water:

1. Use a cup of water with well-stirred ice. The water temperature should be an even 32°F .
2. Submerge the room temperature sensor (TS3) into the water while the Master Controller is normally operating. Check the display for the value. If the sensor shows 32°F , it is working properly.
3. Push PB1 and PB2 simultaneously until the green LED is blinking, scroll down the display to "in", the defrost termination sensor (TS1) value. Submerge the sensor into the water. Check the display for the value. If the sensor shows 32°F , it is working properly.
4. Scroll down the display to "oU", the outlet sensor (TS2) value.
5. Submerge the outlet sensor into the water. Check the display for the value. Again, if the sensor shows 32°F , it is working properly.

Compare the temperature and resistance to Chart A.

Chart A. Temperature/Resistance Characteristics (-50 to 80 °F)

Temp. °F	Temp. °C	ohms*1k		Temp. °F	Temp. °C	ohms*1k
-50	-45.6	43.45		15	-9.4	7.579
-40	-40.0	32.31		20	-6.7	6.731
-35	-37.2	27.96		25	-3.9	5.993
-30	-34.4	24.27		30	-1.1	5.349
-25	-31.7	21.13		32	0	5.123
-20	-28.9	18.43		35	1.7	4.781
-15	-26.1	16.12		40	4.4	4.281
-10	-23.3	14.13		50	10.0	3.454
-5	-20.6	12.42		60	15.6	2.805
0	-17.8	10.94		70	21.1	2.294
5	-15.0	9.651		80	26.7	1.888
10	-12.2	8.544				

NOTE: Use resistance at 32°F for sensor checking.

Pressure Transducer

Your Master Controller will be equipped with one of two types of pressure transducer (PT). The difference is in the color of sensor wires as noted below:

New PT (19-14226, 19-14223)	OLD PT (19-13955, 19-14092)	Description
RED	BLACK	+VDC (+5)
GREEN	WHITE	SIGNAL (1+)
BLACK	GREEN	GROUND (1-)

The **GROUND** is connected to terminal '1-' on the board. The **SIGNAL** lead is connected to terminal '1S' on the board. The **+VDC** lead is connected to terminal '1+' on the board. Chart B shows the characteristics of the pressure transducer. **NOTE: The pressure transducer cannot be repaired but replaced only.**

Chart B. Pressure Sensor Simulation Values (0 to 150 PSIA)

Bar	PSIA	PSIG	V (Signal to Ground)
0	0	-14.6	0.509
0.69	10	-4.6	0.784
1.379	20	5.4	1.058
2.069	30	15.4	1.332
2.758	40	25.4	1.587
3.448	50	35.4	1.862
4.137	60	45.4	2.136
4.827	70	55.4	2.391
5.516	80	65.4	2.665
6.206	90	75.4	2.920
6.895	100	85.4	3.194
7.585	110	95.4	3.469
8.274	120	105.4	3.724

Charging the Master Controller Refrigeration System

Note: If you are a first time installer of a Master Controller system, please call Master-Bilt for on-phone training.

Since the system is designed with free floating head control, the head pressure control valve is not installed in this type of system. Therefore, the compressor operates at its highest EER value.

During initial pull down, after primary charge while the system is running, a large evaporator superheat is built up. The electric expansion valve is then open all the way. If the system is charged full sight glass during this period, the system is already overcharged.

Note: The liquid line size is determined by conventional piping practices for air and electric defrost. For reverse cycle defrost, the liquid line must be selected by choosing the liquid line one nominal step larger than the conventional approach. For example: for an evaporating temperature = -20°F, refrigerant R-404A, and a capacity of 20,000 Btuh, the conventional tables will suggest a liquid line size of 1/2" OD. When utilizing the reverse cycle feature of the Master Controller, the liquid line size should be 5/8" OD. When utilizing the electric or air defrost scheme, there is no need to make the line larger.

All suction lines may be chosen by conventional practices. Please note the "stubs" at both the evaporator and condensing unit do not necessarily mean that this is the correct size for your application.

Calculation of estimated amount of working refrigerant:

The amount of working refrigerant can be estimated by the following formula:

Tons of cooling capacity x 4.5 LBS/Ton + Full Liquid Line Charge between Evaporator and Condensing Unit

For example, a system of 12,000 BTUH @ -20F suction, 50 ft 1/2" liquid line run, R404A, 100F Liquid, the working amount of refrigerant is: $1 \times 4.5 + 6.5 \times 50/100 = 7.75$ LBS R404A. **The actual charge should be approximately this working amount of refrigerant.**

Weight of Refrigerant in LBS per 100 ft of Liquid Line:

Liquid Line Size, Inch	Refrigerant	Lbs of Refrigerant
3/8	R22	4.0
	R404A	3.5
1/2	R22	7.5
	R404A	6.5
5/8	R22	12.0
	R404A	10.5
7/8	R22	24.5
	R404A	21.0

The recommended charging procedures are:

- (1) Charge the system by weighing exact amount of refrigerant specified by Master-Bilt for the unit. Or,
- (2) Charge 50% of the liquid receiver (if provided) rated holding capacity. Let the system run through the pull down period until room temperature is closely reached, then gradually add refrigerant until actual superheat "SH" on board is approaching superheat setpoint "SS". Bubbles may be seen in the sight glass.
- (3) In a reverse cycle defrost system, there may not be a liquid receiver. Charge the system the working amount of refrigerant calculated above. Let the system run through the pull down period until room temperature is closely reached. Then gradually add refrigerant until actual superheat "SH" on board is approaching superheat setpoint "SS". Bubbles may be seen in the sight glass.

How to diagnose an overcharged system:

An overcharged system will not operate properly.

- First, be sure that system is not leaking
- Compressor may be short cycling
- Frost building up on compressor suction section, suction filter or service valve
- Low superheat alarm appears on the controller display constantly
- Head pressure cut-out during defrost for a reverse cycle defrost system

Solution:

Taking some refrigerant out of the system until on-board actual superheat "SH" is observed approaching superheat setpoint "SS".

Technical Notes

- With the optional alarm relay the external temperature and alarm indicator should be connected to "C" (common) and "NC" (normal close) terminals. The alarm does not indicate what causes the alarm. To find out what has caused the alarm, check the onboard two-digit display for alarm codes and refer to the diagnosis chart for corrective action. Thermostat wiring can be used for connection.
- Defrost termination set point (DFTP) can be also set as 50, 70 or 80°F. When setting the defrost termination temperature, make sure that the frost is free after each defrost. Also make adjustments to the maximum defrost duration when necessary.
- The superheat of each application can be set by the customer. Superheat 10-15°F is recommended for winter operation, superheat 5-10°F for summer.
- Always clear the "LS", "rH" and "rL" alarms after corrective action is taken. The sensor and communication alarms cannot be cleared unless they are corrected.
- The wire size for the master/slave communication cable should be 18 to 24 AWG and rated 300 V 80°C or higher. If the wire is rated lower than 300 V, a separate conduit must be used for communication cables.
- Follow the instructions in the Master-Bilt *Condensing Unit and Refrigeration System Installation & Operation Manual* to perform the final check up before charging and starting up the system. Always refer to this service manual, make sure all steps are understood. Don't hesitate to call Master-Bilt Customer Service Department at 800-684-8988 for technical assistance.

Electrical Wiring



WARNING

Please make sure to turn all power off before servicing electrical equipment. Always use a qualified and trained technician. If you are the technician and a first-time installer of a Master Controller system, call our service department at 800-684-8988 for free training and support.

The field wiring for a Master Controller refrigeration system includes the power supply to the condensing unit, the evaporator (fans, heaters and controller) and the communication cables between master and slaves. Thermostat wiring may be used for four-way reversing valve power supply since it is 24 VAC.

TYPICAL WIRING DIAGRAM (AIR DEFROST)

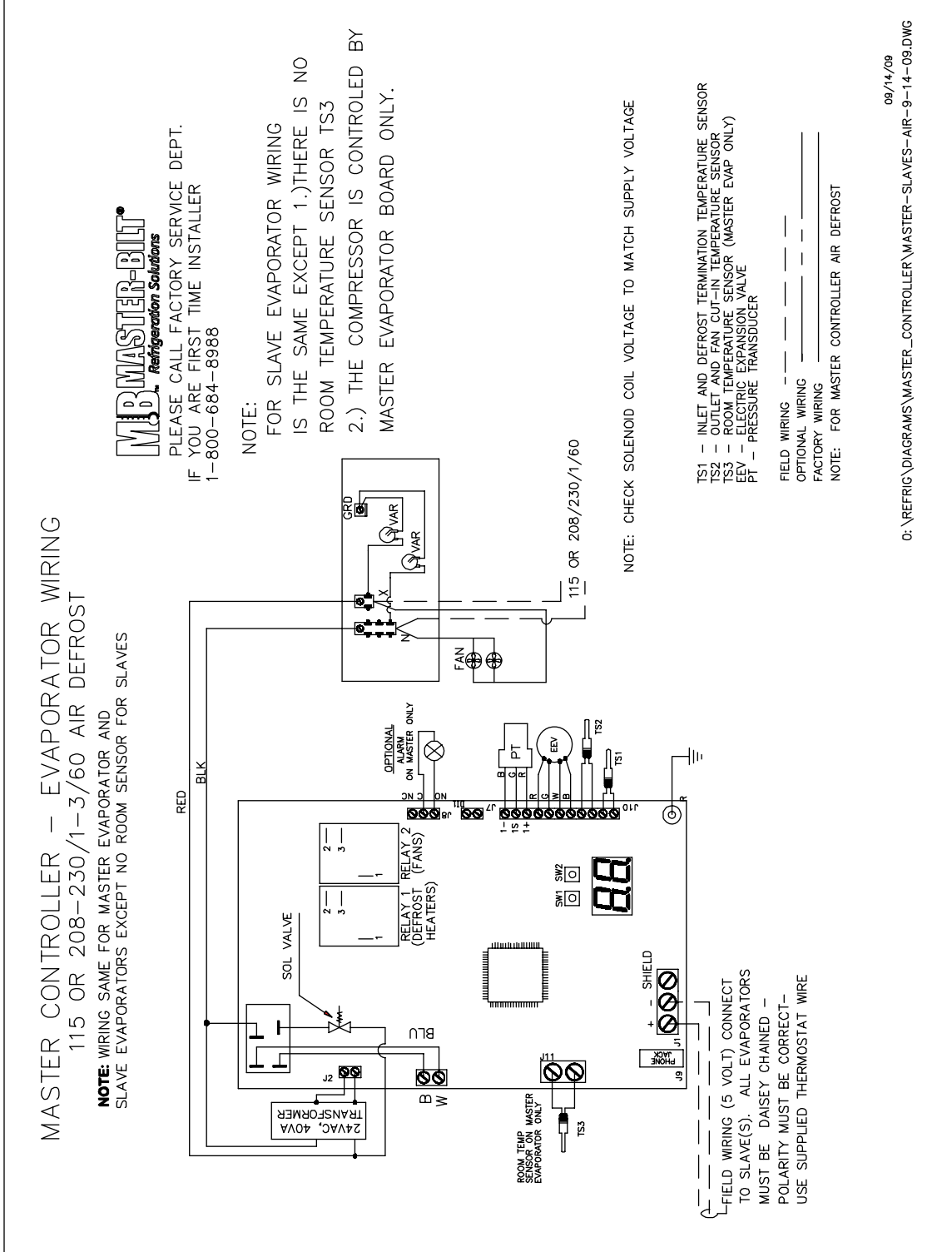

TYPICAL WIRING DIAGRAM (ELECTRIC DEFROST)



PLEASE CALL FACTORY SERVICE DEPT.
IF YOU ARE FIRST TIME INSTALLER
1-800-684-8988

MASTER CONTROLLER - EVAPORATOR WIRING 208-230/1-3/60 ELECTRIC DEFROST

NOTE: WIRING SAME FOR MASTER EVAPORATOR AND
SLAVE EVAPORATORS EXCEPT NO ROOM SENSOR FOR SLAVE

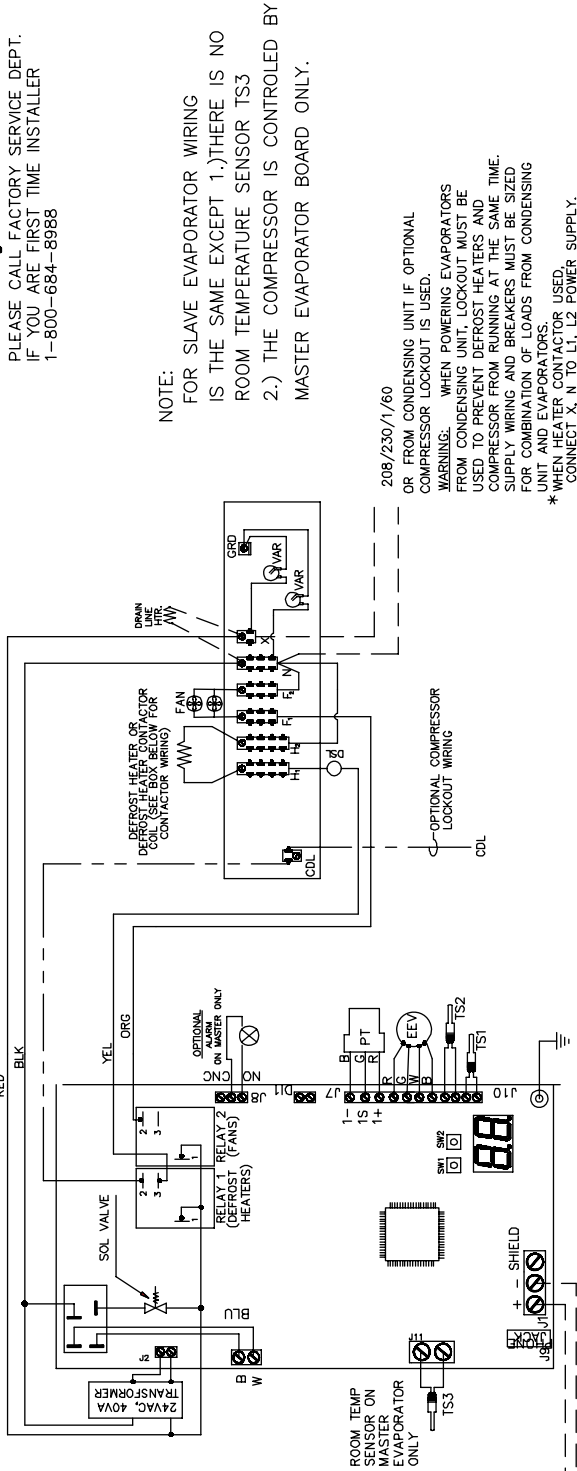

NOTE:
FOR SLAVE EVAPORATOR WIRING
IS THE SAME EXCEPT 1.) THERE IS NO
ROOM TEMPERATURE SENSOR TS3
2.) THE COMPRESSOR IS CONTROLLED BY
MASTER EVAPORATOR BOARD ONLY.

208/230/1/60
OR FROM CONDENSING UNIT IF OPTIONAL
COMPRESSOR LOCKOUT IS USED.
WARNING: WHEN POWERING EVAPORATORS
FROM CONDENSING UNIT, LOCKOUT MUST BE
USED TO PREVENT DEFROST HEATERS AND
COMPRESSOR FROM RUNNING AT THE SAME TIME.
SUPPLY WIRING AND BREAKERS MUST BE SIZED
FOR COMBINATION OF LOADS FROM CONDENSING
UNIT AND EVAPORATORS.
* HEATER LOCKOUT USED.
CONNECT X, N TO L1, L2 POWER SUPPLY.

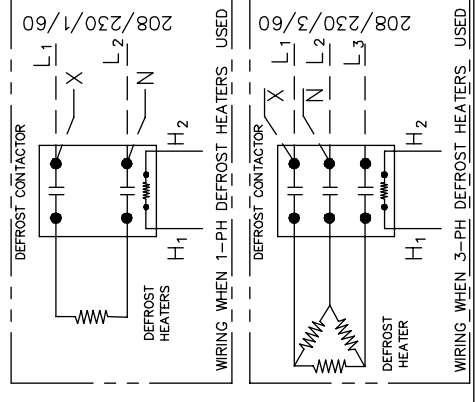
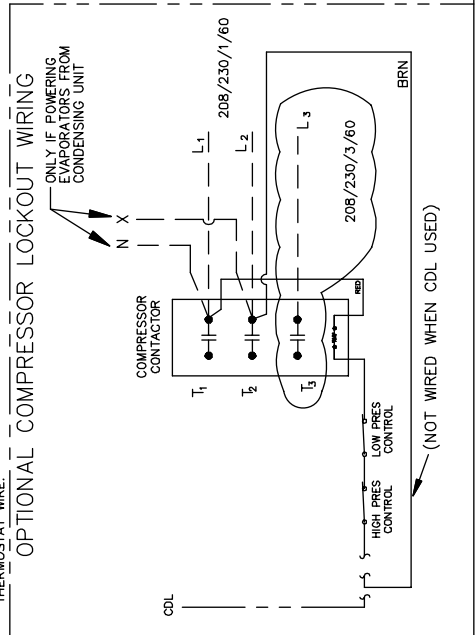

- PT - PRESSURE TRANSDUCER
- TS1 - INLET AND DEFROST TERMINATION TEMPERATURE SENSOR
- TS2 - OUTLET AND FAN CUT-IN TEMPERATURE SENSOR
- TS3 - ROOM TEMPERATURE SENSOR (MASTER EVAP ONLY)
- EEL - ELECTRIC EXPANSION VALVE
- DSI - DEFROST HEATER SAFETY LIMIT SWITCH
- CDL - (OPTIONAL) COMPRESSOR DEFROST LOCKOUT
- FIELD WIRING - - - - -
- OPTIONAL WIRING - - - - -
- FACTORY WIRING - - - - -



REVERSE CYCLE DEFROST

General Information

Master-Bilt's patented (U.S. patent no. 7,073,344) reverse cycle defrost is a standard feature on Master Controller-equipped refrigeration systems. A reverse cycle valve is already **factory-installed** on the condensing unit. The valve's primary function is to reverse the direction of the refrigerant flow during defrost. When the Master Controller's demand defrost determines that a defrost is necessary, the reverse cycle valve is activated and the high temperature refrigerant flow is reversed.

Under the normal refrigeration cycle, the refrigerant flow is the same as traditional refrigeration modes. During the defrost mode, the refrigerant flow is reversed back through the evaporator coil heating it from the inside-out along its entire length and completely eliminating frost buildup (see figure 5 below).

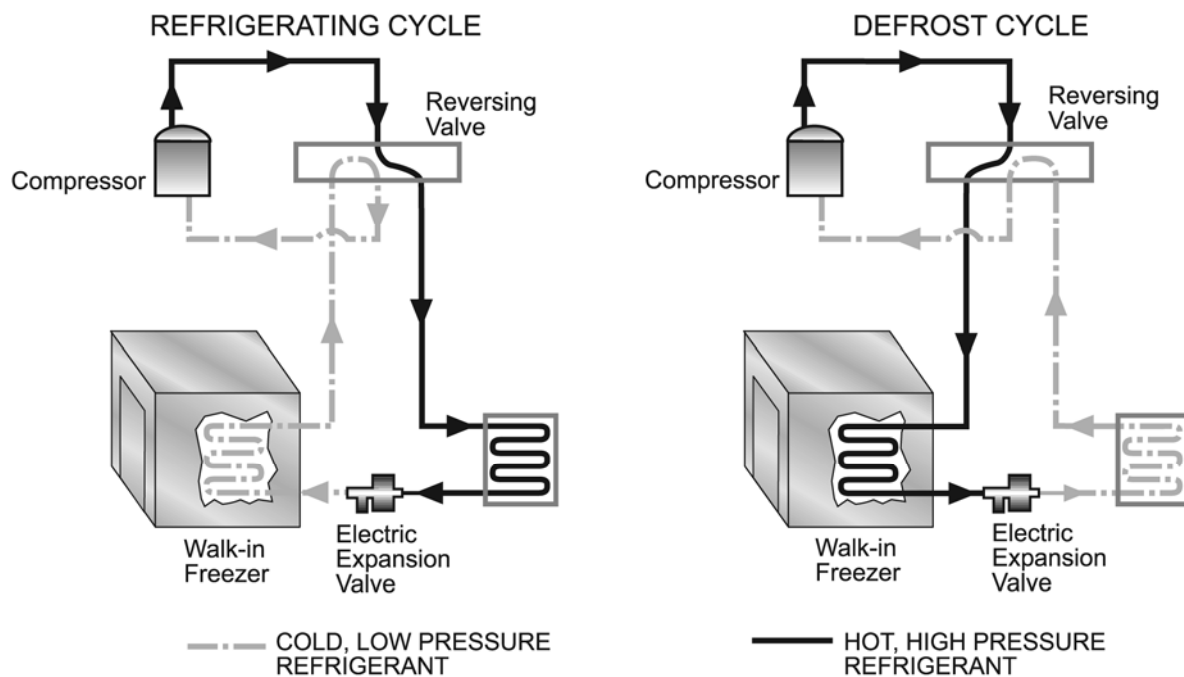

Figure 5

Advantages

Reverse cycle technology offers several significant advantages:

- **An up to 80% reduction in defrost energy usage.** This savings, coupled with that from the demand defrost feature, dramatically reduces energy consumption.
- Eliminates many mechanical parts
- Reduces cost of evaporator, installation and wiring
- Reduces defrost time
- No significant increase in freezer room temperature
- No noticeable increase in product temperature

Factory-Installed Parts

A 4-way reversing valve, operating at 24 VAC, is installed in a reverse cycle defrost unit. A transformer is also installed in the master evaporator to supply 24VAC to the 4-way reversing valve.

Eliminated Parts

The Master-Bilt Reverse cycle's unique technology, coupled with the bi-flow electric expansion valve, eliminates the need for:

- Defrost heaters
- Head pressure control valves
- Check valves and expansion valves at the condenser that are normally necessary in traditional hot gas defrost systems
- By-pass valves
- Liquid line solenoid valves
- Receiver tanks (except in B-series condensing units 6 HP and up)
- Sight glasses

Removing these components reduces the cost of the evaporator itself and saves on installation and wiring.

Defrost Time

Defrost time is greatly lessened with the reverse cycle option. The average time using electric defrost heaters is 20-30 minutes but reverse cycle performs a completely "clean" defrost typically in 3 – 5 minutes for freezers and 1¹/₂ – 2 minutes for coolers. Because the defrost is so rapid, there is no noticeable increase in freezer room temperature and the product temperature rise is also significantly less. Reverse cycle defrost, combined with demand defrost, assures the evaporator receives the number of complete defrosts needed at the necessary times to prevent iced evaporators while assuring the protection of the valued product being stored.

Charging a Master Controller System Equipped with Reverse Cycle Defrost

Note: If you are a first time installer of a Master Controller system, please call Master-Bilt for on-phone training.

Please refer to Page 18: Charging the Master Controller Refrigeration System

Due to the reversing of the refrigerant flow, it is recommended that the refrigeration liquid line piping also be insulated to prevent condensation drips between the condensing unit and the evaporator coil.

TYPICAL WIRING DIAGRAM WITH COPELAND CORESENSE (REVERSE CYCLE DEFROST)

MASTER CONTROLLER – EVAPORATOR WIRING
208-230/1-3/60 REVERSE CYCLE DEFROST
WITH PRESSURE-TEMPERATURE SUPERHEAT CONTROL

NOTE:
FOR SLAVE EVAPORATOR WIRING IS THE SAME EXCEPT 1.) THERE IS NO ROOM TEMPERATURE SENSOR TS3
2.) THE COMPRESSOR IS CONTROLLED BY MASTER EVAPORATOR BOARD ONLY.

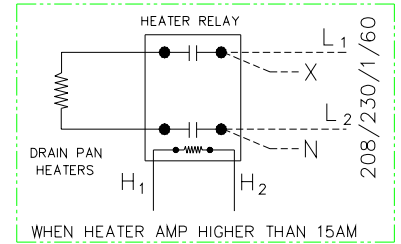
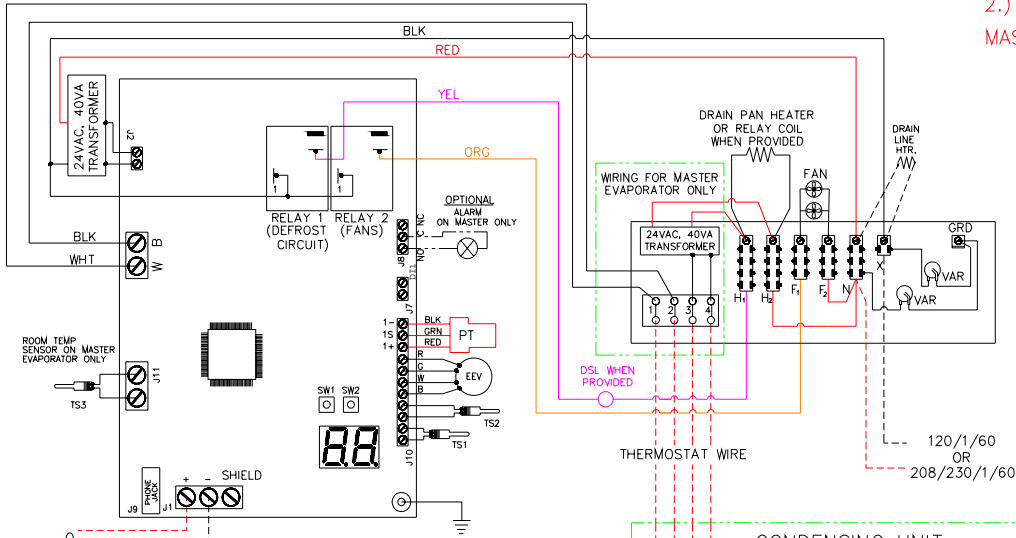

MB MASTER-BILT®
Refrigeration Solutions
PLEASE CALL FACTORY SERVICE DEPT.
IF YOU ARE FIRST TIME INSTALLER
1-800-684-8988

FIELD WIRING (5 VOLT) CONNECT TO SLAVE(S). ALL EVAPORATORS MUST BE DAISEY CHAINED - POLARITY MUST BE CORRECT- USE SUPPLIED THERMOSTAT WIRE

LEGEND:

- TS1 - INLET AND DEFROST TERMINATION TEMPERATURE SENSOR
- TS2 - OUTLET AND FAN CUT-IN TEMPERATURE SENSOR
- TS3 - ROOM TEMPERATURE SENSOR (MASTER EVAP ONLY)
- PT - PRESSURE TRANSDUCER
- EEV - ELECTRIC EXPANSION VALVE
- DSL - DEFROST HEATER SAFETY LIMIT SWITCH
- PT - PRESSURE TRANSDUCER
- FIELD WIRING -----
- FACTORY WIRING _____

O:\REFRIG\DIAGRAMS\MASTER_CONTROLLER\WIRING\
2011\MC-RCD-CORESENSE_08-12-11.DWG

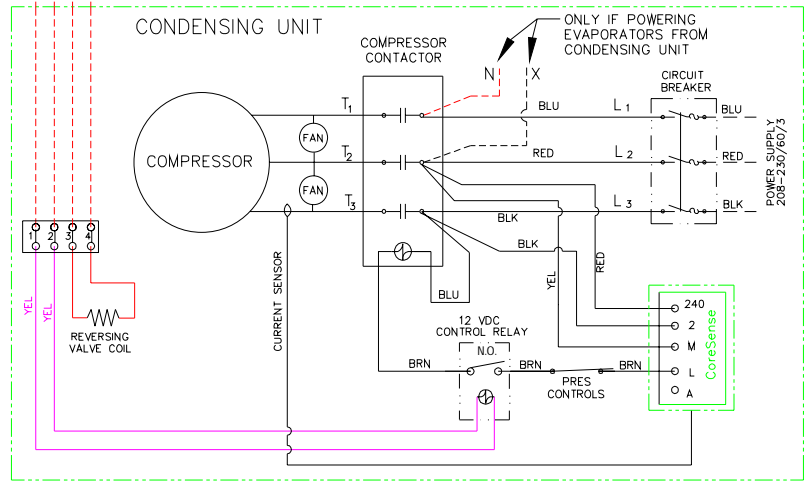

TYPICAL SET POINTS FOR CONTROLLER

		Electric Defrost		Reverse Cycle Defrost	
		Low Temp	High Temp	Low Temp	High Temp
Cn	CMMD	Ao	Ao	Ao	Ao
nS	MSGP	0	0	0	0
SS	SHSP	10	10	10	10
rS	RMSP	-10	35	-10	35
dU	DFTM	35	35	20	20
dS	DFSP	75	45	60	60
PU	PDTM	3	3	3	3
dr	DRTM	2	2	5	2
nd	NMDF	0	0	0	0
HA	HIAL	25	50	25	50
Ad	ALDL	59	59	59	59
LA	LOAL	-20	20	-20	20
oC	OFTM	2	2	2	2
rn	RNTM	2	2	2	2
rP	RNTP	5	3	5	3
PS	MPSP	55	80	55	80
Pn	NPSP	0	0	0	0
Hb	8, 12 24, 48, 72	12	24	12	24
Ar	LGAD	00	00	00	00
Er	DFMD	EL	EL	r1	r1
rr	REFR	4A	4A	4A	4A
AL	DIF2	5	5	5	5

TROUBLESHOOTING GUIDE

Use the alarm display together with the chart below to check the causes of each error message.

Trouble, Alarm Codes	Causes	Corrective Actions
Pressure transducer alarm SP, PRSR	<ul style="list-style-type: none"> • Bad transducer • Out of range • Loose wire • Wrong hook-up 	<ul style="list-style-type: none"> • Replace the pressure transducer • Turn off power for a few seconds, turn back on • Wire correctly
Outlet sensor TS2 fails So SCSR	<ul style="list-style-type: none"> • Mechanical damage • Connection wire loose • Overheated • Out of range 	<ul style="list-style-type: none"> • Tighten the connection wires on the controller terminal • When brazing suction line, take out the sensor • Install the sensor after brazing
Room sensor TS3 fails SA RMSR	<ul style="list-style-type: none"> • Mechanical damage • Connection wire loose • Overheated • Out of range 	<ul style="list-style-type: none"> • Tighten the connection wires on the controller terminal • The room sensor can be replaced by surface sensor
Low superheat LS LOSH	<ul style="list-style-type: none"> • Superheat setting too low • Wrong locations of TS2 • Sensors may be loose • Uneven feeding of coil circuits • Overcharge of refrigerant • Defective electric expansion valve (EEV) • Compressor stops 	<ul style="list-style-type: none"> • Change to correct set point • Make sure the distributor is feeding each circuit evenly • Insulate the sensors with foam tape • Use correct refrigerant charge • Check EEV wiring • Replace defective EEV • Check compressor
High room temperature rH HIRM	<ul style="list-style-type: none"> • Insufficient refrigeration • Heat load too large • Compressor fails or high pressure cuts out • Evaporator fans may not run • Door open for too long • Coil iced-up 	<ul style="list-style-type: none"> • Check system design to select a sufficient system • Replace failed compressor • Fix the evaporator fans • Keep the cold room door closed during refrigeration • Check possible air leak through the walls of cold room
Low room temperature rL, LORM	<ul style="list-style-type: none"> • Inproper low temp setpoint • Over designed system 	<ul style="list-style-type: none"> • Change low temp set point • Re-select the system
Defrost termination sensor TS1 fails Sd, INSR	<ul style="list-style-type: none"> • Mechanical damage • Loose connection wire • Overheated • Out of range 	<ul style="list-style-type: none"> • Tighten the connection wires on the controller terminal • Let the sensor cool down to application temperature range: -50°F to +103°F • Replace failed sensor
Low pressure alarm LP, PAL	<ul style="list-style-type: none"> • Refrigerant leak • Bad transducer 	<ul style="list-style-type: none"> • Fix leak • Replace pressure transducer
Communication CA, CMAL	<ul style="list-style-type: none"> • Loose RS-485 connection • Failed communication port 	<ul style="list-style-type: none"> • Tighten the terminals • Change a new controller board

Troubleshooting the Electric Expansion Valve

If the valve stops moving, depending upon how far open it is, one or more alarms may be displayed. These alarms include a low superheat alarm, a low temperature alarm, and/or a high temperature alarm.

Use the following steps to troubleshoot the valve:

- 1) Disconnect the valve from the controller.
- 2) The resistance between the black and white leads should be 90 ohms. The resistance between the black and red leads should be an open.
- 3) The resistance between the red and green leads should be 90 ohms. The resistance between the white and green leads should be an open.
- 4) The resistance between each lead and the brass housing of the valve should be an open.
- 5) Read the AC, not DC, voltage across the black and white leads while the valve is moving. The AC voltage should be 11 to 13 VAC. The voltage will be close to 0 VAC when the valve is not moving.
- 6) Repeat step 5 across the red and green leads.

If any voltage is out of tolerance, replace the controller. If the above steps pass, inspect for contamination in the valve or nicks on the seat of the valve.

CAUTION: If the valve was taken apart and was left running while taken apart, the piston may have come too far out of the motor assembly. If you reassemble the valve with the piston in this position, the threads in the piston will be stripped when the piston is forced into the seat while tightening the lock nut. Make sure the piston is drawn up far enough into the motor assembly before reassembling.

MASTER-BILT PART NUMBERS

Use the chart below when ordering replacement parts for your Master-Bilt Master Controller refrigeration system.

Item Description	Part Number	Notes
Master Controller Board	19-14153	Please re-set for applications
Electric Expansion Valve	19-13772	Connections: SER-6-1/2"x1/2"
Electric Expansion Valve	19-13773	Connections: SER-6-5/8"x5/8"
Pressure Transducer	19-14223	Suction Pressure
4-Way Reversing Valve	09-09776	7/8" Connections, 24VAC Coil
4-Way Reversing Valve	09-09783	1 3/8" Connections, 24VAC Coil
Evaporator Inlet/Outlet Sensor (Surface Sensor)	19-13968	10 ft Leads
External Control RELAY	19-13855	For solenoid valve or compressor control
24VAC, 40VA Transformer	39-01088	120/208/240 V Primary
6 Pin, 25 ft Data Cable	19-13780	For use with remote panel display
3 Wire, RS-485 for Master/Slave, 20 ft	19-13785	
Valve Test Kit	19-13786	Recommended for service
Controller Mounting Cover Assembly	900-18151	
Remote Panel Display	19-13778	Recommended for service
Thermostat Wire, #18-2, Plastic Jacketed Cable	21-01259	Used for reversing valve and alarm

For condensing unit installation and wiring, please consult the *Master-Bilt Condensing Unit System Installation and Operation Manual*. If any discrepancy is found in this manual, please contact Master-Bilt Technical Service Department immediately.



908 Highway 15 North
New Albany, MS 38652
Service Dept. phone: 800-684-8988
Fax: 866-882-7629
Email: service@master-bilt.com

Rev. 8-11