

MB MASTER-BILT® Refrigeration Solutions



IHC-27

IHC-48

Installation & Operations Manual

Master-Bilt Products
908 Highway 15 North
New Albany, MS 38652
Phone: (800) 684-8988

PN 297-90000
Rev05-10-04 LN

TABLE OF CONTENTS

INTRODUCTION.....	4
STORE CONDITIONS.....	4
WARNING LABELS AND SAFETY INSTRUCTIONS.....	5
PRE-INSTALLATION INSTRUCTIONS.....	6
Inspection for Shipping Damage.....	6
INSTALLATION INSTRUCTIONS.....	6
General Instructions.....	6
Mechanical	6
Electrical.....	7
Leg and Condensate Pan Installation.....	8
SERVICE INSTRUCTIONS	8
TEMPERATURE SENSOR, DEFROST HEATER AND FAN MOTOR REPLACEMENT.....	8
ELECTRONIC REFRIGERATION CONTROL (ERC).....	9
FINAL CHECK LIST.....	14
SENSOR PROBE	14
MASTER-BILT PART NUMBERS	15
ACCESSORIES.....	16
SALE AND DISPOSAL	16
WIRING DIAGRAMS IHC.....	17

INTRODUCTION

Thank you for purchasing a Master-Bilt cabinet. This manual contains important instructions for installing, using, and servicing a Master-Bilt **IHC** case. A parts list is included with this manual. Read all these documents carefully before installing or servicing your equipment.

STORE CONDITIONS

The Master-Bilt **IHC** cases are designed to operate in the controlled environment of an air-conditioned store. The store temperature should be at or below 75°F and a relative humidity of 55% or less. At higher temperature or humidity conditions, the performance of these cases may be affected and the capacity diminished.

The Master-Bilt **IHC** should not be positioned where it is directly exposed to rays of sun or near a direct source of radiant heat or airflow. This will adversely affect the case and will result in poor performance.

If this case is to be located against a wall, there should be at least 4" space between the wall and the back of the case. This space will allow for the circulation of air behind the case, which will prevent condensation on the exterior surfaces.



NOTICE

Read this manual before installing your cabinet. Keep the manual and refer to it before doing any service on the equipment. Failure to do so could result in personal injury or damage to the cabinet.



DANGER

Improper or faulty hook-up of electrical components on the refrigeration units can result in severe injury or death.

All electrical wiring hook-ups must be done in accordance with all applicable local, regional or national standards.



NOTICE

Installation and service of the refrigeration and electrical components of the cabinet must be performed by a refrigeration mechanic and/or a licensed electrician.

The portions of this manual covering refrigeration and electrical components contain technical instructions intended only for persons qualified to perform refrigeration and electrical work. This manual cannot cover every installation, use or service situation. If you need additional information, call or write us:

Customer Service Department
Master-Bilt Products
Highway 15 North
New Albany, MS 38652
Phone (800) 684-8988
Fax (800) 684-8988

WARNING LABELS AND SAFETY INSTRUCTIONS



This symbol is the safety-alert symbol. When you see this symbol on your cabinet or in this manual, be alert to the potential for personal injury or damage to your equipment.

Be sure you understand all safety messages and always follow recommended precautions and safe operating practices.



NOTICE TO EMPLOYERS

You must make sure that everyone who installs, uses or services your cabinet is thoroughly familiar with all safety information and procedures.

Important safety information is presented in this section and throughout the manual. The following signal words are used in the warnings and safety messages:

DANGER: Severe injury or death will occur if you ignore the message.

WARNING: Severe injury or death can occur if you ignore the message.

CAUTION: Minor injury or damage to your cabinet can occur if you ignore the message.

NOTICE: This is important installation, operation or service information. If you ignore the message, you may damage your cabinet.

The warning and safety labels shown throughout this manual are placed on your Master-Bilt Products cabinet at the factory. Follow all warning label instructions. If any warning or safety labels become lost or damaged, call your customer service department at (800) 684-8988 for replacements.

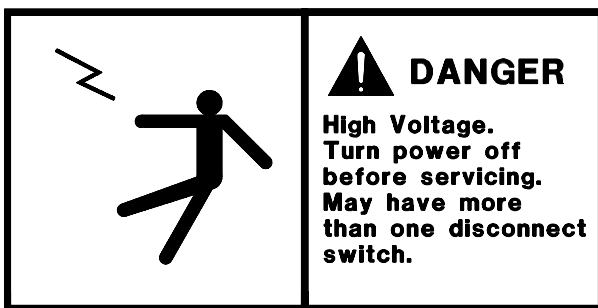

This label is attached to the cabinet power cord label and on the wiring channel.

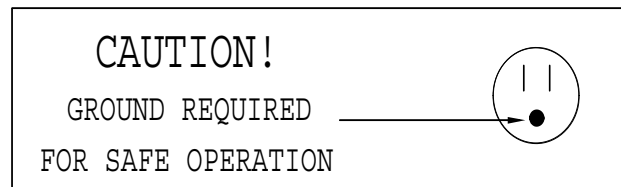

This label is located on top of the electrical control on models with a power cord.

PRE-INSTALLATION INSTRUCTIONS

INSPECTION FOR SHIPPING DAMAGE

You are responsible for filing all freight claims with the delivering truck line. Inspect all cartons and crates for damage as soon as they arrive. If damage is noted to shipping crates or cartons or if a shortage is found, note this on the bill of lading (all copies) prior to signing.

If damage is discovered when the cabinet is uncrated, immediately call the delivering truck line and follow up the call with a written report indicating concealed damage to your shipment. Ask for an immediate inspection of your concealed damage item. Crating material must be retained to show the inspector from the truck line.

INSTALLATION INSTRUCTIONS

GENERAL INSTRUCTIONS

1. Be sure the equipment is properly installed by competent service people.
2. Keep the equipment clean and sanitary so it will meet your local sanitation codes. Clean the cabinet with a mild detergent and water, then rinse.
3. Rotate your stock so that older stock does not accumulate. This is especially important for ice cream. A "First-In, First-Out" rotation practice will keep the products in good salable condition.
4. Do not place product in the case when it is soft or partially thawed. Also, product should not be put in the case for at least 6 hours after it is started.
5. Stock cases as quickly as possible, exposing only small quantities to store temperatures for short periods of time.
6. When replacing burned out fluorescent tubes, be sure that the electrical power to the lighting circuit is turned off.

NOTICE TO STORE OWNERS / MANAGERS

Moisture or liquid around or under the cabinet is a potential slip/fall hazard for persons walking by or working in the general area of the cabinet. Any cabinet malfunction or housekeeping problem that creates a slip/fall hazard around or under the cabinet should be corrected immediately.

If moisture or liquid is observed around or under a Master-Bilt cabinet, an immediate investigation should be made by qualified personnel to determine the source of the moisture or liquid. The investigation should determine if the cabinet is malfunctioning or if there is a drainpipe leaking.

MECHANICAL

Remove front grille and check refrigeration lines to see that they are free (not touching each other or compressor). Spin condenser fan blade to see that it is free.

Check that all service valves (2) are open. Cut compressor hold-down strap and remove. The springs are secured for shipping by either tightening bolts or shipping strap. Remove the strap or loosen the hold-down bolts so that the compressor floats freely. Check all refrigeration lines and electrical conduit for rubbing or chaffing, paying particular attention to area where lines enter the cabinet.

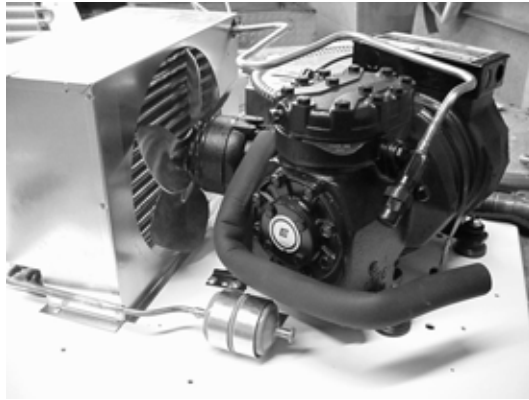

Remove cabinet from crate base and slide into location. Cabinet must be level from side to side and front to back for correct draining of coil pan and for self-closing doors to operate correctly. Allow minimum of 4" between back of cabinet and wall and between top of cabinet and ceiling for proper condensing unit air circulation.

To comply with Sanitation requirements the cabinet must be mounted on legs (6" high min.) or casters or the base must be sealed to the floor with an N.S.F. listed silicone sealant.

To comply with UL requirements the cabinet must have a minimum clearance of 4" at the top, 6" at the rear and 0" at each side.

ELECTRICAL



Before servicing electrical components in the case or the doors or door frames make sure all power to case is off. Always use a qualified technician.

Check voltage and amps drawn on (Page 17) to determine proper line and fuse or circuit breaker size. Check power supply for low voltage. If voltage reads "230" with no load, and it drops below "207" when the compressor tries to start, it is an indication of too small supply wiring or too long to run.

It is recommended that a separate circuit be run for each cabinet to prevent another appliance blowing the fuse or breaker, causing loss of product.

The cabinet should be grounded.

LOW TEMPERATURE FREEZERS – "IHC" Models

The IHC has a power cord (15A, 230 Volt) on top of the cabinet at the right rear for connection to power. On initial start-up the evaporator fan motors will not start and you cannot initiate a defrost until the evaporator coil temperature has lowered to 30°F. This is due to the thermostat. Also, the cabinet comes with a non-adjustable "Front" control to keep the mullion heaters off until the cabinet temperature has lowered to 10°F.

LEG AND CONDENSATE PAN INSTALLATION FOR TOP MOUNT CABINETS ONLY

1. Screw legs into existing crate mounting holes.
2. Mount pan and bracket assembly to rear of cabinet with 2 large sheet metal screws (supplied). Be sure pan is located directly under cabinet drain.

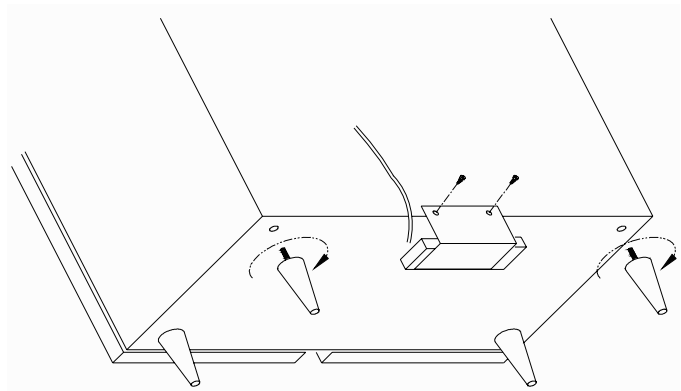

SERVICE INSTRUCTIONS

1. High head pressure and high back pressure:
 - A. Condenser coil clogged or restricted
 - B. Condenser fan motor defective.
 - C. Air discharge in rear of cabinet restricted.
2. Low back pressure and low head pressure:
 - A. Restriction in system.
 - B. Refrigerant undercharged.
 - C. Leak in system
3. Pressure normal – cabinet warm:
 - A. Coil blocked with frost (see #4).
 - B. Refrigerant undercharged.
 - C. Control set too warm.
4. Cabinet not cycling – coil blocked with frost:
 - A. Defective temperature controller.
 - B. Refrigerant overcharged.
 - C. Location too hot.
 - D. Condenser clogged.
 - E. Condenser fan motor defective.
 - F. Defrost heater not operating.
5. Compressor starts and runs – but cycles on overload:
 - A. Low voltage
 - B. Relay defective.
 - C. Overload defective.
 - D. High head pressure (see #1).

Temperature sensor, defrost heater and fan motor replacement

Before making any change, technician should:

1. Disconnect power to the cabinet
2. Remove screws from venturi and pull down

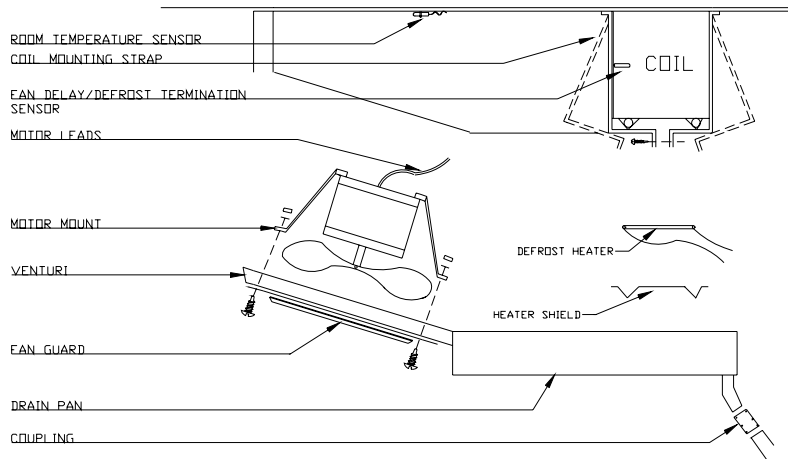

To change a temperature sensor (cabinet zone sensor or defrost termination sensor), simply disconnect the sensor wires from the controller and replace the new sensor in the original position. Use plastic tie to tighten the zone sensor. Insert the sensor for defrost termination firmly into the evaporator coil, in between the fins. Make sure the sensor wires do not touch or are not close to any heater rods.

To change defrost heater – remove screws from drain pan and pull down – remove screws from coil mounting straps – spring straps open – remove heater shield – pull heater out of slots in coil fins.

To change fan motor – disconnect fan motor leads – remove screws from fan guards and motor mounts.

ERC 2 – ELECTRONIC REFRIGERATION CONTROL

Programming

The ERC 2 control initially powers up displaying 12:00 AM otherwise it will show the last configured selection (time or temperature). If a power outage occurs during normal operation, the control will maintain the correct time-of-day using a capacitor (batteries are not required). The time will be maintained for up to 100 hours when the capacitor is fully charged.

To initiate a **Manual Defrost**, press and hold the MAN DEF key for 3 seconds.

There are two levels of programming in the ERC 2. The first level of security will enable the user to set two parameters: Time-of-day (**CLoC**) and Set point temperature (**SEt**). The other level allows access to the other parameters.

Three buttons are used for the programming: SET, UP and DOWN

To access the pushbuttons on the ERC2, flip up the front cover using the tabs on the side of the cover as shown.

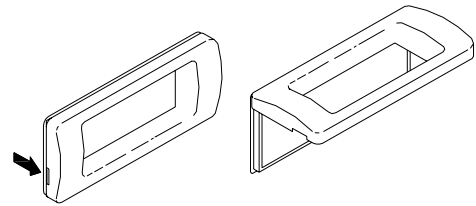
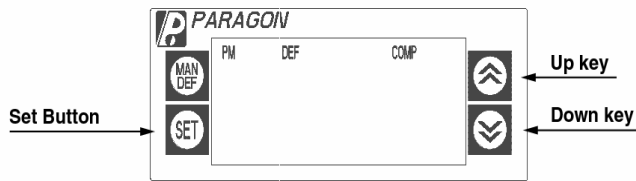

Display Lay-out

To change time-of-day and set point temperature (First Level) follows these steps:

Step 1		Press and hold set for 5 seconds. The display will show CLoC
Step 2		Press SET again to change the time-of-day
Step 3	or	Press UP or DOWN until the correct time-of-day is displayed
Step 4		Press SET to accept the new time
Step 5		Press DOWN to go to the next parameter – Set point Temperature - (cut out)
Step 6		Press SET to change the set point temperature
Step 7	or	Press UP or DOWN to go to the desired set point. The range is – 40 to 60°F or –40 to 16°C
Step 8		Press SET to accept the change
Step 9		Press DOWN to exit the first level of programming

Note 1: During programming, if no button is pushed during 30 seconds, the control will go back to the normal operating mode. This is valid for both programming levels.



Note 2: When changing the time, press and hold the MAN DEF button for 3 seconds to change the AM/PM mode.

Note 3: Master-Bilt's Set point Temperature (**Set**) is set at a recommended –10°F at the factory for low temperature(LT) and +35°F for medium temperature(MT) application.

Note 4: If demand defrost (**ddEF**) is used, the minimum number of defrost is 1 per 24 hours.

To change the other parameters (Second Level) follow these steps:

Step 1	and	Press and hold SET and DOWN for 10 seconds. The display will show dSPL
Step 2		Press SET to change the parameter
Step 3	or	Press UP or DOWN to change the options, time or temperature for the current parameter

Step 4		Press SET to accept the new value
Step 5		Press DOWN to go to the next parameter, then go back to Step 2. After the last parameter is displayed (ALHi), the display will go back to the normal operating condition

Note: to scroll down the parameters without changing them, press the **DOWN** button.

List of Parameters

Time_of_Day Scheduled Defrost Default Settings for 19-13822. Apply to IHC

Here is a list of the parameters that can be changed in the Second Level of programming, as well as their options and ranges.

Note: Master-Bilt's Set point Temperature (**Set**) is set at a recommended -25°F at the factory for IHC low temperature(LT).

If demand defrost (ddEF) is used, the minimum number of defrost is 1 per 24 hours.

Parameter	Display Symbol	Description	Range / Options	Master-Bilt's Factory Setting
Display Status	dSPL	Information shown on the display during operation conditions	tdAy – time-of-day rSP^o – zone temperature CyCL – cycle between time and zone temperature Epr^o – evaporator coil temperature	rSP
Clock Format	CLHr	Time Format (12 or 24 hours mode)	12Hr – AM/PM format 24Hr – 24 hour format	12Hr
Temperature Format	°dSP	Temperature degrees	°F – degrees Fahrenheit °C – degrees Celsius	°F
Defrost Type	dFtP	Type of defrost used in the application	ELEC – electric defrost / off cycle HgAS – hot gas defrost	ELEC
Fan Status During Defrost	EFAN	Enable or not the fan during defrost	no – fan is turned off during defrost yES – fan remains on during defrost	no
Fan Status During Normal Mode	CFAN	Enable or not fan during normal compressor on/off mode	on – fan on during normal mode CyCP – fan cycles with compressor	on
Defrost Interval	dFin	Type of defrost interval	TdAy – time-of-day setpoint CPrn – compressor run time tdEF – temperature initiated defrost ddEF – demand initiated defrost	TdAy <i>(if CPrn, use 8hrs; if TdAy, use 6 am, 2pm and 10pm)</i>
Minimum Compressor Off Time	CoFF	Minimum time that the compressor will remain turned off	Range: from 0 to 15 min	2
Minimum Compressor On Time	Con	Minimum time that the compressor will remain turned on	Range: from 0 to 15 min	2

Alarm Delay	ALrd	Time delay before the alarm goes off after temperature fall off the two alarm set points	Range: from 0 to 59 min	30
Number of Defrosts	nodF	Number of defrosts per day	from 0 to 8 (0 means 1 defrost every 48 hours)	3
Defrost Start Time	dEF1-8	Start time of each defrost	Hour and minute selectable (<i>def0 default = 1AM</i>) (dEF1 default = 6 AM), (dEF2 default = 2 PM), (dEF3 default = 10 PM), (dEF4 default = 12 AM), (dEF5 default = 3 PM), (dEF6 default = 3 AM), (dEF7 default = 9 PM), (dEF8 default = 9 AM)	
Defrost Duration	dEFd	Defrost duration time (back-up for defrost termination temperature)	Range: from 0 min to 4 hours	35
Fan Delay	FAnd	Delay time for the fan after defrost (back-up for fancut-in temperature)	Range: from 0 to 15 min	2
Pump Down	Pudn	Pump down duration	Range: from 0 to 59 min	0
Drip Time	driP	Drip time duration	Range: from 0 to 59 min	2
Setpoint Differential	diF°	Cut-in temperature differential Note: cut-in is cut-out plus differential	Range: from 1 to 25°	5° F
Temperature Initiated Defrost	tdEF	Temperature that will initiate a defrost cycle	Range: from – 40 to 40°F or – 40 to 4°C	(Not used) in this case
Defrost Termination Temperature	dEF°	Temperature in the evaporator that will terminate the defrost cycle	Range: from 0 to 75°F or –18 to 25°C	50° F
Fan Cut-In Temperature	FAn°	Temperature in the evaporator that will turn the fan on after defrost	Range: from – 40 to 60°F or – 40 to 23°C	30°F
Low Temperature Alarm	ALLo	Low temperature setpoint that will make the alarm go off and the error message appear on the display	Range: from – 40 to 83°F or – 40 to 23°C	-40°F
High Temperature Alarm	ALHi	High temperature setpoint that will make the alarm go off and the error message appear on the display	Range: from – 40 to 83°F or –40 to 23°C	50°F

Important Note: To change from degrees **C** to **F** or vice-versa, the user must reprogram all the parameters that are related to the temperature. The unit does not convert the parameters automatically from degrees **F** to **C** or vice-versa.

Example 1 - To adjust the time-of-day

- Press and hold SET for 5 seconds
- Press SET again
- Press UP or DOWN until the correct time appears on the display
- Press SET to accept the new time
- Press DOWN twice to exit the programming mode

Example 2 - To set one defrost a day, at 11:59 PM

- Press and hold SET and DOWN for 10 seconds
- Press DOWN five times to get to go to the Defrost Interval (**dFln**)
- Press SET to change the parameter
- Press DOWN until **tdAy** appears on the display
- Press SET to accept the option
- Press DOWN seven times to go to the Number of Defrosts (**noDF**)
- Press SET to change it
- Press UP or DOWN until **1** appears on the display
- Press SET to accept the change
- Press DOWN to go to Defrost Start Time (**dEF1**)
- Press SET to change the time
- Press UP or DOWN until the **11:59** PM appears on the display
- Press SET
- Press DOWN ten times to exit the programming level

Error Codes

Display	Control Status
Er 1	ERC Fault – software or hardware failure
Er 2	ERC Communication Fault – indicates that there is a problem with the display module cable
Er 3	Zone Sensor Fault – indicates an open or shorted temperature sensor
Er 4	Evaporator Sensor Fault – indicates an open or shorted evaporator sensor
Er 5	ERC Fault – software or hardware failure
Er 6	Low Temperature Alarm – indicates that the temperature has dropped below the low alarm setpoint
Er 7	High Temperature Alarm – indicates that the temperature has gone above the high alarm setpoint
Er 8	Relay and display modules are incompatible

For Error Codes 1, 2 and 5 cut the power to the unit and correct the problem to reset the display. For Codes 3 and 4, press the UP or DOWN button on the display to reset the error message. If the display still shows the message, the sensor must be replaced. The Error Codes 6 and 7 will be automatically reset once the temperature is back within the two set points.

FINAL CHECK LIST

- A. Check operating pressures.
- B. Check electrical requirements of unit to supply voltage.
- C. Set temperature control for desired temperature range.
- D. Check sight glass (if applicable) for proper refrigerant charge.
- E. Check system for proper defrost settings and operation.
- F. Check condensing unit for vibrating or rubbing tubing. Dampen and clamp as required.
- G. All valves should be completely opened counter-clockwise.
- H. Check packing nuts on all service valves.
- I. Replace all service valve caps and latch unit covers.

SENSOR PROBE

NOTICE: If the probe assembly is disconnected from the main board during normal operation (unit running), the connectors must be installed in the same position that they had before disconnection (P1 and P2), otherwise the control will not function properly.

The Electronic Refrigeration Control sensors have NTC thermistors. The reference resistance is 30,000 ohms at 77°F (25°C). It carries NTC thermistors with a range of -40° to 199° F. In case there is a failure, these sensors should be used in replacement of the sensors shipped with the control. In order to diagnose faults in the probe, the control has LED functions as a diagnostic tool. When power is supplied to the control, the LED will turn on and will remain on as long as this condition is satisfied. When there is a fault in the probe, the LED will blink intermittently. When this occurs, the probe assembly needs to be replaced. If power is supplied to the control and the LED remains off, there is a failure in the main relay control and it needs to be replaced.

In case of a probe failure, the control will go into a safety mode of operation. While in safety mode the control ignores probe inputs and cycles the compressor on for 5 minutes and off for 3 hours. The LED will be blinking and signalling that there is something wrong with the probe. To replace the sensor probes, disconnect power to the control, replace the probes and restart the unit. Since the wire is fixed to the cabinet, a technician may cut the sensor wire inside the cabinet and splice it with a new sensor.

SENSOR PROBE TEMPERATURE AND RESISTANCE

Temperature		Resistance
°F	°C	Ohms
-29.2	-34	683,100
-20.2	-29	499,200
-9.4	-23	347,100
-0.4	-18	259,500
10.4	-12	185,200
19.4	-7	141,200
30.2	-1	103,100
32.0	0	97,950
39.2	4	80,040
50.0	10	59,700
60.8	16	45,000
69.8	21	35,820
80.6	27	27,500
89.6	32	22,210

MASTER-BILT PART LIST

The table below gives Master-Bilt part numbers. Use this chart when ordering replacement parts for your **IHC** cabinets. Always Advise Cabinet Serial Number When Ordering Parts

Description	IHC-27	IHC-48
Cabinet Frame Heater		17-09151
Coil Defrost Heater	17-00442	17-09076
Compressor	03-14403	03-14242
Condensate Heater	17-09084	17-09084
Condenser Coil	07-13076	07-13090
Condenser Fan Blade	15-13093	15-13093
Condenser Fan Guard		25-01278
Condenser Fan Motor	13-01283	13-01283
Controller Kit*	19-13761	19-13761
10' Cable	19-13760	19-13760
Controller Display	19-13756	19-13756
T-Sensor (2)	19-13758	19-13758
CRO Valve	09-00992	09-00987
Door Frame Heater	17-09063	17-09063
Door Gasket	37-01207	37-01211
Door Hinge-Inner Doors-L.H.		35-01451
Door Hinge-Inner Doors-R.H.	35-01452	35-01452
Door Hinge-Outer Doors	35-01450	35-01450
Door Trim	29-01481	29-01380
Drain Line Heater	17-09063	17-09063
Drain Pan Heater		17-09075
Drier	09-09171	09-00987
Evaporator Coil	07-00750	07-13084
Evaporator Fan Blade	15-01184	15-01184
Evaporator Fan Guard	25-00205	25-01278
Evaporator Fan Motor	13-00683	13-00683
Expansion Valve	09-09543	09-09543
Female Plug	21-00577	
Front Control	19-00899	19-00899
Heater Safety Control	19-01307	19-01307
Leg	27-00558	27-00558
Power Switch	19-13168	19-13168
Shelves (Cantilever)	33-01519	33-01518
Sight Glass		09-09505
Vibration Eliminator		09-00140

Accessories

Description	IHC-27	IHC-48
Casters (4) 5" diameter	A297-11140	A297-11140
Tray Slides		
9/16" lip ledge for 12" X 20" or 18" X 26" pans (must specify)	A340-21100	
1-3/16" bottom ledge for 12" X 20" or 18" X 26" pans (must specify)		A340-21200
Voltage Boosting Transformer	39-01080	39-01080

SALE AND DISPOSAL

OWNER RESPONSIBILITY

If you sell or give away your Master-Bilt cabinet you must make sure that all safety labels and the Installation - Service Manual are included with it. If you need replacement labels or manuals, Master-Bilt will provide them free. Contact the customer service department at Master-Bilt at (800) 684-8988.

The customer service department at Master-Bilt should be contacted at the time of sale or disposal of your cabinet so records may be kept of its new location.

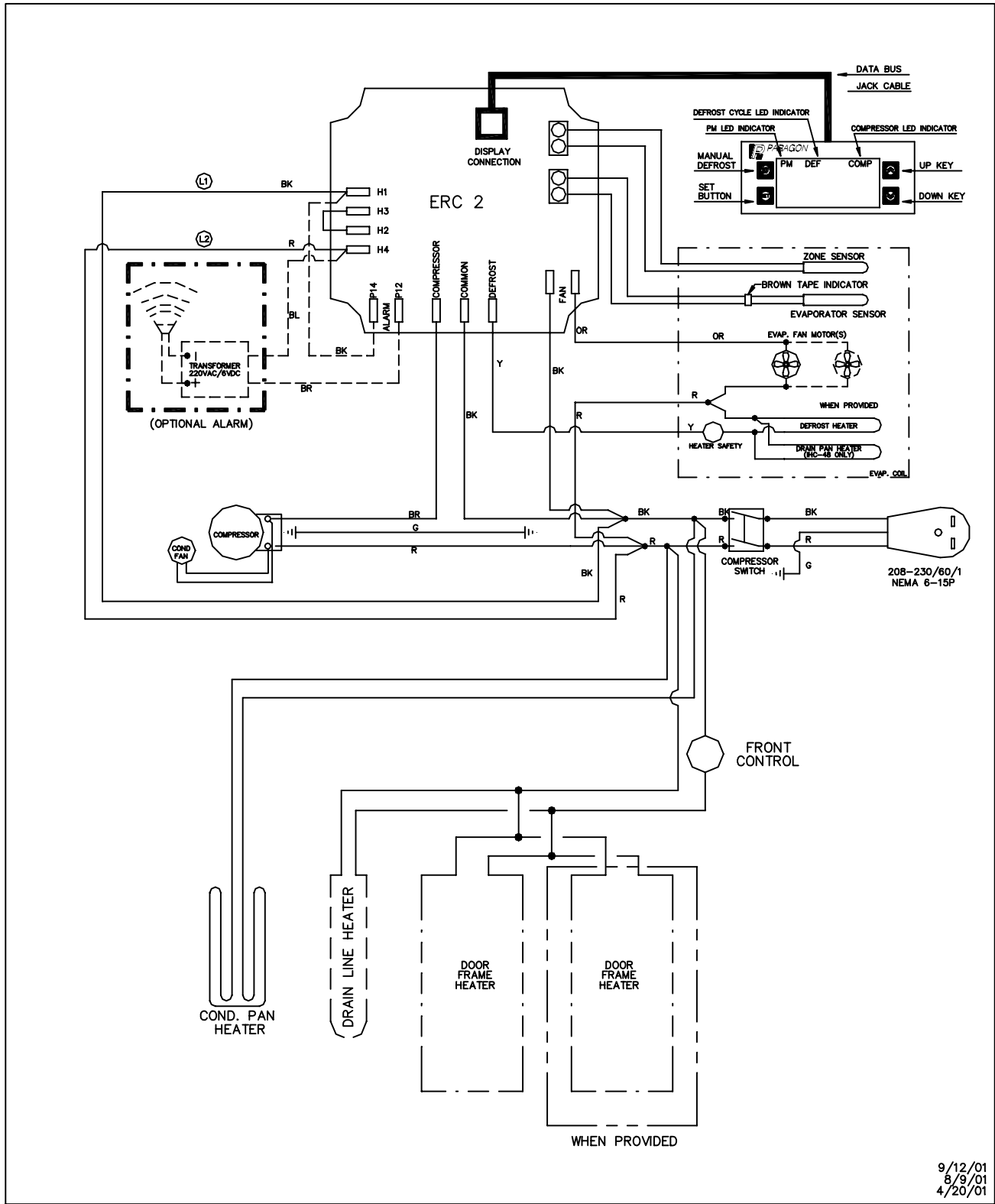

9/12/01
8/9/01
4/20/01

WIRING DIAGRAM IHC-27, -48 WITH ERC2 ELECTRONIC CONTROL

IHCERC