

MB MASTER-BILT® Refrigeration Solutions

FIP-40 with Dixell Controller



Installation & Operations Manual

Master-Bilt Products
908 Highway 15 North
New Albany, MS 38652
Phone: (800) 684-8988

PN 070-90000
Rev 05/05/06 LN

TABLE OF CONTENTS

INTRODUCTION.....	3
STORE CONDITIONS.....	3
WARNING LABELS AND SAFETY INSTRUCTIONS.....	4
PRE-INSTALLATION INSTRUCTIONS.....	5
Inspection for Shipping Damage.....	5
INSTALLATION INSTRUCTIONS.....	5
General Instructions.....	5
Mechanical.....	5
Location.....	5
SERVICE INSTRUCTIONS.....	6
Electrical.....	6
Special Service Situations.....	6
Operating Conditions and Pressures.....	6
Temperature Sensor, Defrost Heater, and Fan Motor Replacement.....	6
Dixell Electronic Refrigeration Control.....	7
Operations.....	7
Defrost & Manual Defrost.....	7
Temperature Setpoint.....	7
List of Parameters.....	8
Alarm Signals.....	9
Electrical Connections.....	9
Probe Connections.....	9
SENSOR PROBE TEMP. AND RESISTANCE.....	9
FAN OPERATION & VIBRATION, VOLTAGE CHECK.....	9
FINAL CHECK LIS.....	10
MASTER-BILT PARTS LIST.....	10
SALE AND DISPOSAL.....	11
WIRING DIAGRAM	12-13

INTRODUCTION

Thank you for purchasing a Master-Bilt cabinet. This manual contains important instructions for installing, using, and servicing a Master-Bilt **FIP-40** case. A parts list is included with this manual. Read all these documents carefully before installing or servicing your equipment.

STORE CONDITIONS

The Master-Bilt **FIP-40** cases are designed to operate in the controlled environment of an air-conditioned store. The store temperature should be at or below 75°F and a relative humidity of 55% or less. At higher temperature or humidity conditions, the performance of these cases may be affected and the capacity diminished.

The Master-Bilt **FIP-40** should not be positioned where it is directly exposed to rays of sun or near a direct source of radiant heat. This will adversely affect the case and will result in poor performance.



NOTICE

Read this manual before installing your cabinet. Keep the manual and refer to it before doing any service on the equipment. Failure to do so could result in personal injury or damage to the cabinet.



DANGER

Improper or faulty hook-up of electrical components on the refrigeration units can result in severe injury or death.

All electrical wiring hook-ups must be done in accordance with all applicable local, regional or national standards.



NOTICE

Installation and service of the refrigeration and electrical components of the cabinet must be performed by a refrigeration mechanic and/or a licensed electrician.

The portions of this manual covering refrigeration and electrical components contain technical instructions intended only for persons qualified to perform refrigeration and electrical work.

This manual cannot cover every installation, use or service situation. If you need additional information, call or write us:

Customer Service Department
Master-Bilt Products
Highway 15 North
New Albany, MS 38652
Phone (800) 684-8988
Fax (800) 684-8988

WARNING LABELS AND SAFETY INSTRUCTIONS



This symbol is the safety-alert symbol. When you see this symbol on your cabinet or in this manual, be alert to the potential for personal injury or damage to your equipment.

Be sure you understand all safety messages and always follow recommended precautions and safe operating practices.



NOTICE TO EMPLOYERS

You must make sure that everyone who installs, uses or services your cabinet is thoroughly familiar with all safety information and procedures.

Important safety information is presented in this section and throughout the manual. The following signal words are used in the warnings and safety messages:

DANGER: Severe injury or death will occur if you ignore the message.

WARNING: Severe injury or death can occur if you ignore the message.

CAUTION: Minor injury or damage to your cabinet can occur if you ignore the message.

NOTICE: This is important installation, operation or service information. If you ignore the message, you may damage your cabinet.

The warning and safety labels shown throughout this manual are placed on your Master-Bilt Products cabinet at the factory. Follow all warning label instructions. If any warning or safety labels become lost or damaged, call your customer service department at (800) 684-8988 for replacements.

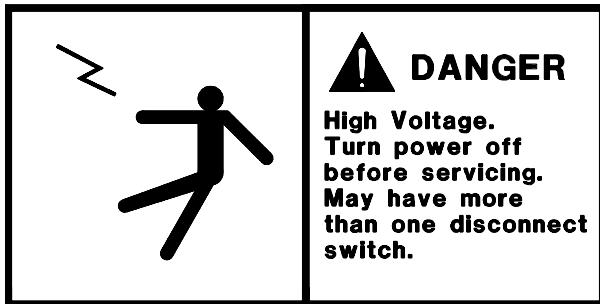

*This label is located on top of the electrical control
This label is attached to the cabinet power cord
label and on the wiring channel.*

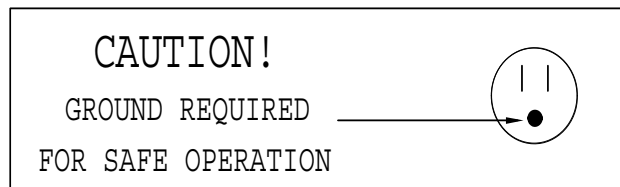

on models with a power cord.

PRE-INSTALLATION INSTRUCTIONS

INSPECTION FOR SHIPPING DAMAGE

You are responsible for filing all freight claims with the delivering truck line. Inspect all cartons and crates for damage as soon as they arrive. If damage is noted to shipping crates or cartons or if a shortage is found, note this on the bill of lading (all copies) prior to signing.

If damage is discovered when the cabinet is uncrated, immediately call the delivering truck line and follow up the call with a written report indicating concealed damage to your shipment. Ask for an immediate inspection of your concealed damage item. Crating material must be retained to show the inspector from the truck line.

INSTALLATION INSTRUCTIONS

GENERAL INSTRUCTIONS

1. Be sure the equipment is properly installed by competent service people.
2. Keep the equipment clean and sanitary so it will meet your local sanitation codes. Clean the cabinet with a mild detergent and water, then rinse.
3. Rotate your stock so that older stock does not accumulate. This is especially important for ice cream. A "First-In, First-Out" rotation practice will keep the products in good salable condition.
4. Do not place product in the case when it is soft or partially thawed. Also, product should not be put in the case for at least 6 hours after it is started.
5. Stock cases as quickly as possible, exposing only small quantities to store temperatures for short periods of time.
6. When replacing burned out fluorescent tubes, be sure that the electrical power to the lighting circuit is turned off.

MECHANICAL

Remove front grille and check refrigeration lines to see that they are free (not touching each other or compressor). Spin condenser fan blade to see that it is free.

LOCATION

Remove cabinet from crate base and slide into location. Cabinet must be level from side to side and front to back for correct draining of coil pan and for self-closing doors to operate correctly.

To comply with Sanitation requirements the cabinet must be sealed to the floor with a N.S.F. listed silicone sealant, mounted on casters, or with 6" minimum legs. 0" air space is required for the front and each side. The top and back of the cabinet must be left open for compliance.

Remove shipping supports from bottom edge and top edge of doors.

SERVICE INSTRUCTIONS

ELECTRICAL



WARNING

Before servicing electrical components in the case or the doors or door frames make sure all power to case is off. Always use a qualified technician.

It is recommended that a separate circuit be run for each cabinet to prevent another appliance blowing the fuse or HAC&R C/B, causing loss of product. This circuit should be sized according to the amp rating on the cabinet data label.



NOTICE

For models with electronic ballast only:



For replacement ballast, use only ballast that complies with UL Type CC rating if unit is equipped with electronic ballast.

SPECIAL SERVICE SITUATION:

A. There are rare occasions when the refrigerant charge must be evacuated from a cabinet in order to perform service work. In those situation, Master-Bilt recommends that a refrigerant reclaimer be used according to the EPA guidelines to eliminate the possibility of refrigerant being released to the atmosphere.

B. If moisture or liquid is observed around or under a Master-Bilt cabinet, an immediate investigation should be made by qualified personnel to determine the source of the moisture or liquid. The investigation made should determine if the cabinet is malfunctioning or if there is a simple housekeeping problem. Moisture or liquid around or under a cabinet is a potential slip/fall hazard for persons walking by or working in the general area of the cabinet. Any cabinet malfunction or housekeeping problem that creates a slip/fall hazard around or under a cabinet should be corrected immediately.

OPERATING CONDITIONS AND PRESSURES

With room ambient temperature of +80 F and cold cabinet (unit cycling on control):

Suction Pressure	2 to 5 psig
Head Pressure	240 to 260 psig

TEMPERATURE SENSOR, DEFROST HEATER, AND FAN MOTOR REPLACEMENT



WARNING Before making any change, the technician should disconnect power to the cabinet.

To change a temperature sensor (cabinet zone sensor or defrost termination sensor), simply disconnect the sensor wires from the controller and replace the new sensor in the original position. Use plastic tie to tighten the zone sensor. Insert the sensor for defrost termination firmly into the evaporator coil, in between the fins. Make sure the sensor wires do not touch or are not close to any heater rods.

To change defrost heater – remove screws from drain pan and pull down – remove screws from coil mounting straps – spring straps open – remove heater shield – pull heater out of slots in coil fins.

To change fan motor – disconnect fan motor leads – remove screws from fan guards and motor mounts.

MASTER-BILT ELECTRONIC REFRIGERATION CONTROL

OPERATION

Compressor When power is first turned on to the control, the LED indicator under COMP on the display starts blinking. After one-minute delay the compressor comes on. The COMP LED indicator stays on while compressor relay is energized. Display will show actual box temperature. Figure 4 is the display layout. The compressor will be cycled off when the actual box temperature reaches its set point. The COMP indicator will be off.





Fig. 4 – Display Lay-out

Fan The fans will run constantly except when a defrost is initiated, or when the evaporator temp is above the 30°F. When in defrost mode the fan is off until the end of the defrost and the 2 minute drip time has passed. There is 4 minutes delay after a defrost before the fan comes on. The difference of the evaporator and room temperature of more than 9°F will override the fan delay. FAN LED indicator is on while FAN relay is energized.

Defrost The control uses demand defrost with at least one defrost per day for oil return safety. The control can be used for scheduled defrost. A programmed “HOT-KEY” has to be used to re-set the defrost scheme for special applications. During defrost the display will show dEF and the LED indicator under DEF in on.

MANUAL DEFROST

1. Push this **DEFROST**  key for more than 2 seconds and a manual defrost will start.
2. While in defrost, Push and hold the **DEFROST**  key for more than 5 seconds and the controller will end the defrost cycle. The controller will then enter drip mode for 2 minutes. The DEF led is flashing in drip mode.

HOW TO SEE THE SETPOINT(Box temperature cut-out)

1.  Push and immediately release the **SET** key: the display will show the Set point value;
2. Push and immediately release the **SET** key or wait for 5 seconds to display the probe value (actual box temperature) again.

HOW TO CHANGE THE SETPOINT

1. Push the **SET** key for more than 2 seconds to change the Set point value;
2. The value of the set point will be displayed and the LED under COMP starts blinking;
3. To change the Set value push the **UP** ▲ or **DOWN** ▼ arrows within 10s.

To memorize the new set point value push the **SET** key again or wait 10s.

HOW TO CHANGE a parameter value



1. Enter the Programming mode by pressing the **SET** and **DOWN ▼** keys for 3 seconds (LEDs under DEF and COMP start blinking).
2. Select the required parameter by pushing the **UP ▲** or **DOWN ▼** arrows
3. Press the “**SET**” key to display its value (now only the COMP LED is blinking)
4. Use “**UP**” or “**DOWN**” to change its value
5. To exit: Press **SET + UP ▲** or wait 15s without pressing a key.

NOTE 1: The set value is stored even when the procedure is exited by waiting the time-out to expire.

NOTE 2: Master-Bilt’s SETPOINT is set at a recommended -10°F at the factory for low temperature(LT).

NOTE 3: To scroll down the parameters without changing them, press the DOWN button.

LIST OF PARAMETERS

Here is a list of the parameters the value of which can be changed in the programming mode, as well as their ranges.

Parameter	Display Symbol	Description	Range	Master-Bilt’s Setting
				FIP-40
Temperature Set Point	Set	When this temperature is reached the compressor LED will be off	-16 to 5°F	-10° F
Temperature Differential	Hy	Cut-out temperature is Set + Hy	1 to 255°F	10
Maximum Temperature Alarm	ALU		230°F	50° F
Minimum Temperature Alarm	ALL		-58°F	-40° F – for LT 32° F – for MT
Temperature Alarm Delay	Ald		0 to 255 min	30
Room Probe display	dP1			
Evaporator Probe Display	dP2			

ALARM SIGNALS

Message	Cause	Outputs
“P1”	Room probe failure	Compressor output according to par. “Con” and “COF”
“P2”	Evaporator probe failure	Defrost end is timed
“HA”	Maximum temperature alarm	Outputs unchanged.
“LA”	Minimum temperature alarm	Outputs unchanged.

NOTE:

Probe alarms “P1” and “P2” start some seconds after the fault in the related probe; they automatically stop some seconds after the probe restarts normal operation. Check connections before replacing the probe.

Temperature alarms “HA” and “LA” automatically stop as soon as the thermostat temperature returns to normal values and when defrost starts.

ELECTRICAL CONNECTIONS

The controller is provided with screw terminal block to connect cables with a cross section up to 14 AWG. (2,5 mm²). Before connecting cables make sure the power supply complies with the control’s requirements. Separate the probe cables from the power supply cables, from the outputs and the power connections. Do not exceed the maximum current allowed on each relay, in case of heavier loads use a suitable external relay.

PROBE CONNECTIONS

The probes shall be mounted with the bulb upwards to prevent damages due to casual liquid infiltration. It is recommended to place the thermostat probe away from air streams to correctly measure the average room temperature. Place the defrost termination probe among the evaporator fins in the coldest place, where most ice is formed, far from heaters or from the warmest place during defrost, to prevent premature defrost termination.

SENSOR PROBE TEMPERATURE AND RESISTANCE

Temperature		Resistance
°F	°C	Ohms
-29.2	-34	683,100
-20.2	-29	499,200
-9.4	-23	347,100
-0.4	-18	259,500
10.4	-12	185,200
19.4	-7	141,200
30.2	-1	103,100
32.0	0	97,950
39.2	4	80,040
50.0	10	59,700
60.8	16	45,000
69.8	21	35,820
80.6	27	27,500
89.6	32	22,210

FAN OPERATION AND VIBRATION; VOLTAGE CHECK

Check the operation of the fan blade and also check for vibration noises due to refrigerant lines rattling against one another. While the cabinet is in operation, check the voltage draw and the amperage draw versus this rating on the nameplate. Voltage should be checked at the compressor terminals while the compressor is initially starting. The FIP-40 models are designed to operate at +/- 10% of 115/60/1. This means at time of start-up, the voltage should be between 103 volts and 126.5 volts at the compressor.

FINAL CHECK LIST

- A. Check operating pressures.
- B. Check electrical requirements of unit to supply voltage.
- C. Set temperature control for desired temperature range.
- D. Check system for proper defrost settings and operation.
- E. Check condensing unit for vibrating or rubbing tubing. Dampen and clamp as required.

MASTER-BILT PART LIST

The table below gives Master-Bilt part numbers. Use this chart when ordering replacement parts for your **FIP-40** cabinets. Always Advise Cabinet Serial Number When Ordering Parts

Description	FIP-40
Ballast, Electronic 2-Lamp	23-01693
Coil Defrost Heater	17-09407
Compressor	03-14799
Condenser Coil	07-13241
Condenser Fan Blade	15-13093
Condenser Fan Motor	13-00311
Condenser Fan Motor Bracket	13-13165
Contractor	19-13936
Front Grille	67-18101 (White)
Rear Grille	67-102(White) 67-202 (Black)
Door Frame Heater	17-09083
Door Gasket	37-01313
Door Hinge	35-01450
Drain Line Heater	17-00404
Drier	09-09171
Door Handle	35-01612
Dixell Controler	19-13918
Dixell Sensor Assy 20'	19-13932
Evaporator Coil	07-13288
Evaporator Fan Blade	15-13072
Evaporator Fan Guard	25-01280
Evaporator Fan Motor	13-13075
Expansion valve (FBSE-1/4-2P-BP/05)	09-09757
Fluorescent Lamp, 36" (F25T8CW)	23-01577
Front Glass	31-02470

Heater Safety Control	19-01164
Lamp Switch (Toggle)	19-13118
Leg Leveler, each	27-00592
Pilaster 24"	33-01488
Pilaster Clips	33-01011
Plastic Drain Assy	11-01759
Power Cord	21-00312
Rocker Switch	23-01673
Shelf,	33-01721

SALE AND DISPOSAL

OWNER RESPONSIBILITY

If you sell or give away your Master-Bilt cabinet you must make sure that all safety labels and the Installation - Service Manual are included with it. If you need replacement labels or manuals, Master-Bilt will provide them free. Contact the customer service department at Master-Bilt at (800) 684-8988.

The customer service department at Master-Bilt should be contacted at the time of sale or disposal of your cabinet so records may be kept of its new location.

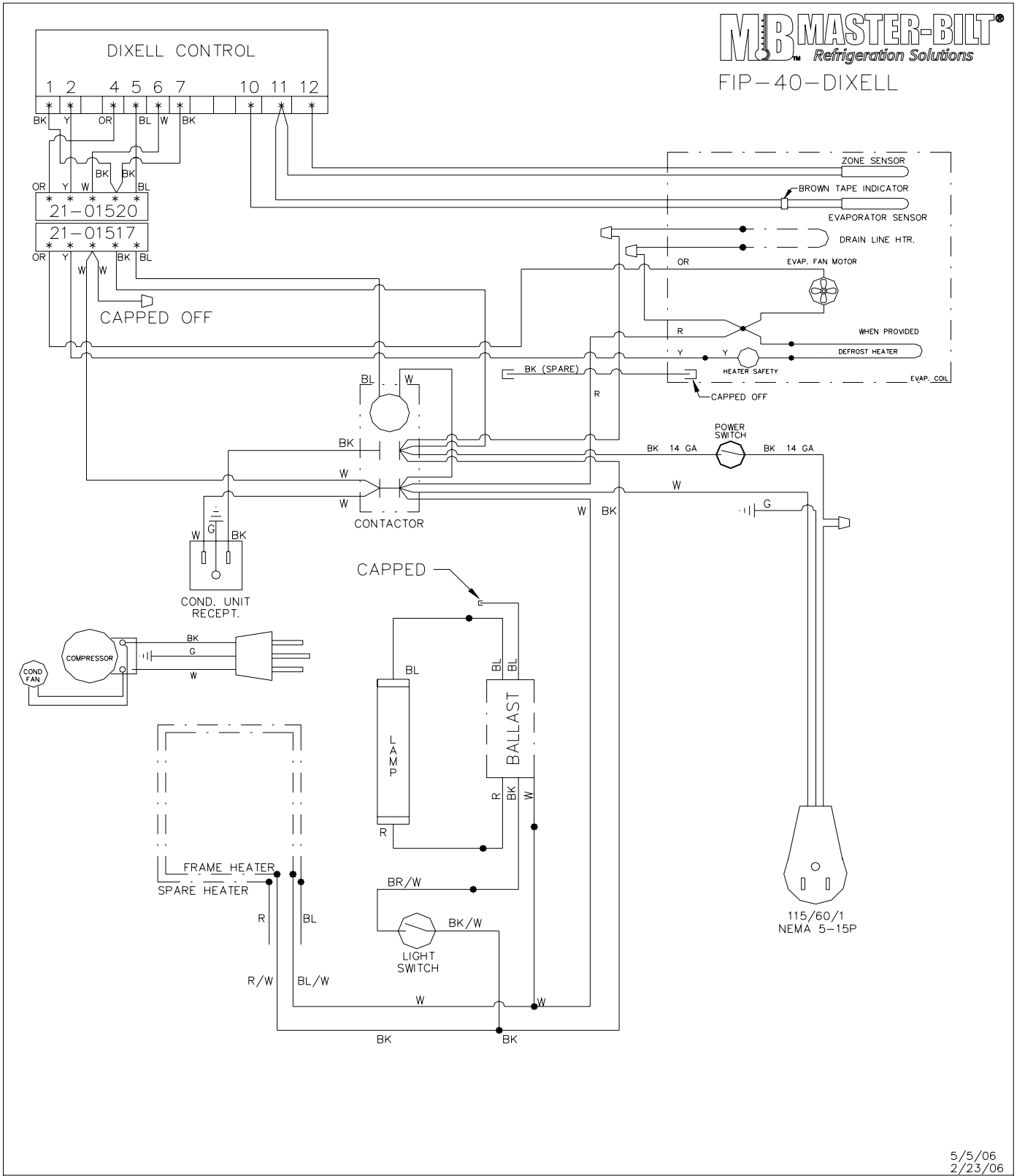

5/5/06
2/23/06

WIRING DIAGRAM FIP-40
WITH DIXELL ELECTRONIC CONTROL

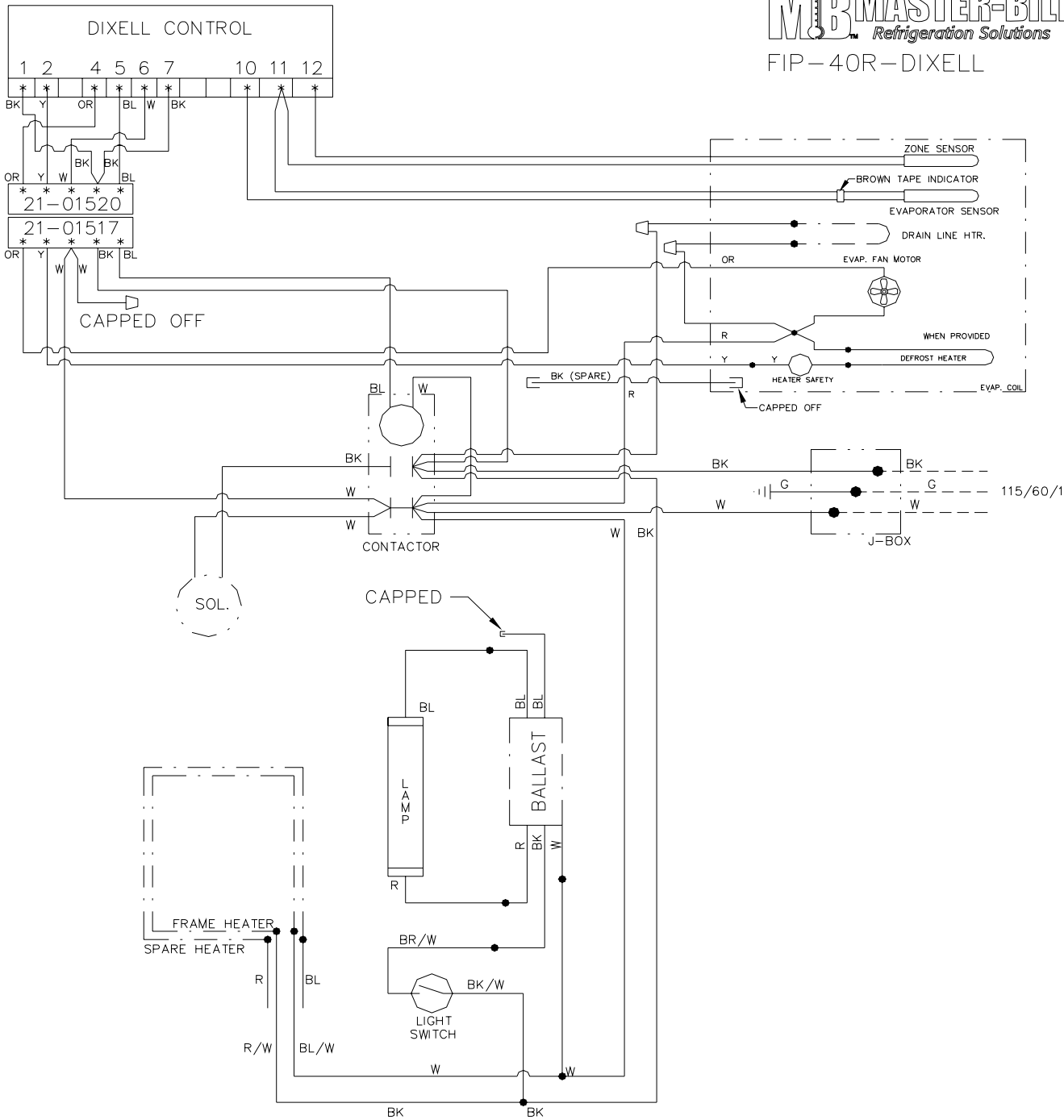

5/5/06
2/24/06

WIRING DIAGRAM FIP-40R
WITH DIXELL ELECTRONIC CONTROL

FIP-40R-DIXELL