

MB MASTER-BILT®

™ *Refrigeration Solutions*

DCIFLR

DCIFLR

DCIFLR

Installation & Operations Manual

Master-Bilt Products
908 Highway 15 North
New Albany, MS 38652
Phone: (800) 684-8988

PN 075-90000
Rev3-6-08

TABLE OF CONTENTS

INTRODUCTION	4
STORE CONDITIONS	4
WARNING LABELS AND SAFETY INSTRUCTIONS	5
PRE-INSTALLATION INSTRUCTIONS	6
Inspection for Shipping Damage.....	6
INSTALLATION INSTRUCTIONS	6
General Instructions.....	6
Electrical.....	6
REPLACING CONDENSATE HEATERS	7
TEMPERATURE CONTROL	7
CLEANING INSTRUCTIONS	7
SERVICE INSTRUCTIONS	8
MASTER-BILT PART NUMBERS	9
SALE AND DISPOSAL	11
WIRING DIAGRAM	12

INTRODUCTION

Thank you for purchasing a Master-Bilt cabinet. This manual contains important instructions for installing, using and servicing a Master-Bilt **DC/FLR** case. A parts list is included in with this manual. Read all these documents carefully before installing or servicing your equipment.

STORE CONDITIONS

The Master-Bilt **DC/FLR** cases are designed to operate in the controlled environment of an air-conditioned store. The store temperature should be at or below 75°F and a relative humidity of 55% or less. At higher temperature or humidity conditions, the performance of these cases may be affected and the capacity diminished. It is not uncommon in a newly constructed store for the temperature and humidity to be above design conditions. These excessive conditions may produce sweating in the case until the store is operational and the ambient environment is more desirable.

The Master-Bilt **DC/FLR** should not be positioned where it is directly exposed to rays of sun or near a direct source of radiant heat or airflow. This will adversely affect the case and will result in poor performance.

If this case is to be located against a wall there should be at least 4" space between the wall and the back of the case. This space will allow for the circulation of air behind the case, which will prevent condensation on the exterior surfaces.



NOTICE

Read this manual before installing your cabinet. Keep the manual and refer to it before doing any service on the equipment. Failure to do so could result in personal injury or damage to the cabinet.



DANGER

Improper or faulty hook-up of electrical components of the refrigeration units can result in severe injury or death.

All electrical wiring hook-ups must be done in accordance with all applicable local, regional or national standards.



NOTICE

Installation and service of the refrigeration and electrical components of the cabinet must be performed by a refrigeration mechanic and/or a licensed electrician.

The portions of this manual covering refrigeration and electrical components contain technical instructions intended only for persons qualified to perform refrigeration and electrical work. This manual cannot cover every installation, use or service situation. If you need additional information, call or write us:

Customer Service Department
Master-Bilt Products
Highway 15 North
New Albany, MS 38652
Phone (800) 684-8988
Fax (866) 882-7629

WARNING LABELS AND SAFETY INSTRUCTIONS



This symbol is the safety-alert symbol. When you see this symbol on your cabinet or in this manual, be alert to the potential for personal injury or damage to your equipment.

Be sure you understand all safety messages and always follow recommended precautions and safe operating practices.



NOTICE TO EMPLOYERS

You must make sure that everyone who installs, uses or services your cabinet is thoroughly familiar with all safety information and procedures.

Important safety information is presented in this section and throughout this section and throughout the manual. The following signal words are used in the warnings and safety messages:

DANGER: Severe injury or death will occur if you ignore the message.

WARNING: Severe injury or death can occur if you ignore the message.

CAUTION: Minor injury or damage to your cabinet can occur if you ignore the message.

NOTICE: This is important installation, operation or service information. If you ignore the message, you may damage your cabinet.

The warning and safety labels shown throughout this manual are placed on your Master-Bilt Products cabinet at the factory. Follow all warning label instructions. If any warning or safety labels become lost or damaged, call your customer service department at (800) 684-8988 for replacements.

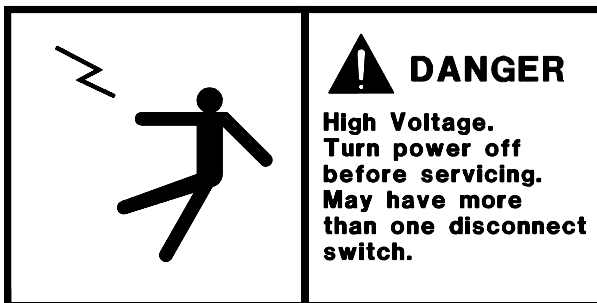

This label is located on top of the electrical control label and on the wiring channel.

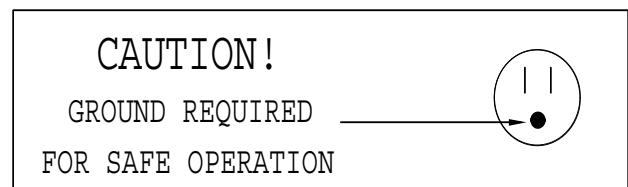

This label is attached to the cabinet power cord on models with a power cord.

PRE-INSTALLATION INSTRUCTIONS

INSPECTION FOR SHIPPING DAMAGE

You are responsible for filing all freight claims with the delivering truck line. Inspect all cartons and crates for damage as soon as they arrive. If damage is noted to shipping crates or cartons or if a shortage is found, note this on the bill of lading (all copies) prior to signing.

If damage is discovered when the cabinet is uncrated, immediately call the delivering truck line and follow up the call with a written report indicating concealed damage to your shipment. Ask for an immediate inspection of your concealed damage item. Crating material must be retained to show the inspector from the truck line.

INSTALLATION INSTRUCTIONS

GENERAL INSTRUCTIONS

1. Be sure the equipment is properly installed by competent service people.
2. Keep the equipment clean and sanitary so it will meet your local sanitation codes.
3. Rotate your stock so that older stock does not accumulate. This is especially important for ice cream. A "First-In, First-Out" rotation practice will keep the products in good salable condition.
4. Do not place product in the case when it is soft or partially thawed. Also, product should not be put in the case for at least 6 hours after it is started.
5. Stock cases as quickly as possible, exposing only small quantities to store temperatures for short periods of time.
6. After removing Power Cord from compressor compartment be sure both power connections to thermostat are securely in place.

NOTICE TO STORE OWNERS / MANAGERS

Moisture or liquid around or under the cabinet is a potential slip/fall hazard for persons walking by or working in the general area of the cabinet. Any cabinet malfunction or housekeeping problem that creates a slip/fall hazard around or under the cabinet should be corrected immediately.

If moisture or liquid is observed around or under a Master-Bilt cabinet, an immediate investigation should be made by qualified personnel to determine the source of the moisture or liquid. The investigation should determine if the cabinet is malfunctioning or if there is a drainpipe leaking.

ELECTRICAL



Before servicing electrical components in the case, make sure all power to case is off. Always use a qualified technician.

To comply with N.S.F. requirements, this cabinet must be mounted on casters or the base must be sealed to the floor with NSF listed silicone sealant. Optional casters screw into the holes from which the shipping bolts were removed.

1. Place cabinet in desired location, leaving approximately 4" behind cabinet to allow condenser discharge air to escape.
2. Check the electrical circuit to see that 115-volt single-phase service is available with sufficient amperage to carry the load of the cabinet. Electrical codes make it necessary to ship the cabinet with 3 prong plugs. However, if it is necessary to use an adapter for a 2-prong outlet, care should be taken to see that a grounding wire is run individually to the cabinet (see wiring diagram).
3. It is unnecessary to remove the grille from your freezer prior to starting of the freezer. All cabinets are equipped with internal spring mounted compressors. All refrigeration valves are shipped open from the factory to eliminate the requirement of opening the service valves upon start-up.
4. Each freezer comes with a thermostatic control pre-set for normal operation. When cooler or warmer temperatures are desired, turn knob in the appropriate direction (clockwise for colder) as indicated on the dial plate. It is suggested that the freezer be allowed to operate at least 4 hours prior to readjustment of the control. It is suggested that the cabinet be allowed to pull down to the desired temperature and cycle off on the control at least three times before product is placed in the freezer.

REPLACING CONDENSATE HEATERS

The cabinet is constructed with a stainless steel top. Directly below the all vinyl collar that encases the openings in the top of your freezer, there is an anti-sweat heater that helps prevent condensation under extreme humidity conditions. This heater is easily replaced by merely removing the plastic collar without the need to dismantle the entire top portion of your freezer.

TEMPERATURE CONTROL

WARNING: KEEP HANDS OR ANY MATERIAL OFF THE FAN BLADE AS FAN MAY COME ON AUTOMATICALLY.

The **DC/FLR** cabinet has a temperature control that is adjustable from #1 (warmest setting) to #9 (coldest setting). Turn the control knob in line with the punch mark to the desired setting. The temperature control is located near the condensing unit.

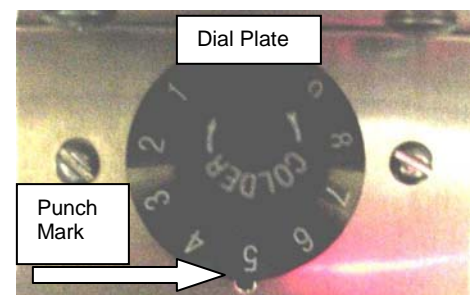

CLEANING

WARNING: DO NOT REMOVE FROST WITH A KNIFE, PICK, OR SHARP OBJECTS. DO NOT USE ABRASIVE CLEANERS OR CAUSTIC CLEANERS OR SCOURING PADS

Wipe the cabinet exterior with a mild detergent and warm water. Rinse and wipe dry with a soft cloth. This cabinet comes with a floor drain to assist in removing excess cleaning solution. When cleaning the cabinet interior, remove product and place the product in a suitable location. Unplug the power to the cabinet. Remove the garden hose-fitting cap and drain plug. Attach a garden hose and route to a floor drain or suitable receptacle and allow cabinet to defrost. Wash the interior with a mild detergent and warm water solution, rinse and dry with a soft cloth. Remove garden hose and attach the hose-fitting cap and drain plug. Plug the cabinet power plug into a wall receptacle and allow the cabinet to reach operating temperature before restocking the product.

SERVICE INSTRUCTIONS (Trouble Shooting Guide)

1. High head pressure and high back pressure:
 - A. Condenser coil clogged or restricted.
 - B. Condenser fan motor defective.
 - C. Air in the system.
 - D. Refrigeration overcharge.
2. Low back pressure and low head pressure:
 - A. Capillary tube restriction.
 - B. Refrigerant undercharged.
 - C. Leak in system.
3. Pressures normal – cabinet warm:
 - A. Refrigerant undercharged.
 - B. Control set too warm.
4. Compressor starts and runs – but cycles on overload:
 - A. Low voltage.
 - B. Overload protector defective.
 - C. High head pressure (see#1).
5. Compressor will not start – hums, but cycles on overload:
 - A. Low voltage.
 - B. Relay defective.
 - C. Overload defective.
 - D. High head pressure (see #1).
6. Cabinet sweating:
 - A. High ambient humidity.
 - B. Defective condensate heater.
7. Special service situations:

If moisture or liquid is observed around or under a Master-Bilt cabinet, an immediate investigation should be made by qualified personnel to determine the source of moisture or liquid. The investigation made should determine if the cabinet is malfunctioning or if there is a simple housekeeping problem. Moisture or liquid around or under a cabinet is a potential slip/fall hazard for persons walking by or working in the general area of the cabinet.

Any cabinet malfunction or housekeeping problem that creates a slip/fall hazard around or under a cabinet should be corrected immediately.

MASTER-BILT PART NUMBERS

The table below gives Master-Bilt part numbers. Use this chart when ordering replacement parts for your **DC/FLR** cases.

Description	DC-2S	DC-4D	DC-4S	DC-6D	DC-8D	DC-10D	DC-12D	FLR-60	FLR-80
Capillary Tube	11-01305	11-01305	11-01305	11-01305	11-01307	11-01307	11-01307	11-01305	11-01307
Compressor	03-14254	03-14254	03-14254	03-14254	03-14255	03-14255	03-14406	03-14254	03-14255
Condenser coil	07-01180	07-01180	07-01180	07-01180	07-01180	07-01180	07-01180	07-01180	07-01180
Condenser Fan Blade	15-13092	15-13092	15-13092	15-13092	15-13092	15-13092	15-13092	15-13092	15-13092
Condenser Fan Motor	13-13101	13-13101	13-13101	13-13101	13-13101	13-13101	13-13101	13-13101	13-13101
Divider	25-00105	25-00103	25-00105	25-00103	25-00103	25-00103	25-00103	25-00103	25-00103
Drier	09-09309	09-09309	09-09309	09-09309	09-09308	09-09308	09-09308	09-09309	09-09308
Grille	25-00104	25-00104	25-00104	25-00104	25-00104	25-00104	25-00104	25-00104	25-00104
Heater	17-09297	17-09293	17-09298	17-09294	17-09299	17-09295	17-09296	17-09298	17-09298
Lid, Double	N/A	44-00471	N/A	44-00471	44-00471	44-00471	44-00471	N/A	N/A
Lid, Single	44-00470	N/A	44-00470	44-00470	N/A	44-00470	N/A	44-00470	44-00470
Power Cord	21-01201	21-01201	21-01201	21-01201	21-01201	21-01201	21-01201	21-01201	21-01201
Temperature Control	19-13607	19-13607	19-13607	19-13607	19-13607	19-13607	19-13607	19-13607	19-13607
Vinyl Collar,63-1/4"	37-00518	N/A	37-00518	37-00518	N/A	37-00518	N/A	37-00518	37-00518
Vinyl Collar,85-1/4"	N/A	37-00516	N/A	37-00516	37-00516	37-00516	37-00516	N/A	N/A
Leg Leveler	27-00592	27-00592	27-00592	27-00592	27-00592	27-00592	27-00592	27-00592	27-00592

DC SERIES Options

PART NO.	DESCRIPTION	SHIP WT. LB/KG
	CASTERS	
A039-11140	Set of 4, 2" diameter casters for DC-2S, DC-4S, DC-4D, DC-6D and DC-8D	4/2
A044-11140	Set of 6, 2" diameter for for DC-10D and DC-12D	5/2
	LEG KITS	
A039-11170	6" leg kit for DC-2S, DC-4S, DC-4D, DC-6D and DC-8D	18/8
A044-11170	6" leg kit for DC-10D and DC-12D	26/12
	LID LOCKING KITS - LESS LOCKS	
A041-11129	For DC-2S and DC-4D	3/1
A051-11229	For DC-4S	5/2
A043-11129	For DC-6D and DC-8D	5/2
A044-11129	For DC-10D and DC-12D	6/3
	LIDS	
44-00470	Single lid for DC models	5/2
44-00471	Double lid for DC models	9/4
	LOAD LEVEL SHELVES	
A039-18127	Load level shelf for DC-2S	*
A040-18127	Load level shelf for DC-4S	*
A041-18127	Load level shelf for DC-4D	16/7
A042-18127	Load level shelf for DC-6D	20/9
A043-18127	Load level shelf for DC-8D	22/10
A044-18127	Load level shelf for DC-10D	24/11
A045-18127	Load level shelf for DC-12D	*
	DIPPER WELL	
A060-20400	With installation kit for all DC models	4/2

* Contact factory

SALE AND DISPOSAL

OWNER RESPONSIBILITY

If you sell or give away your Master-Bilt cabinet you must make sure that all safety labels and the Installation - Service Manual are included with it. If you need replacement labels or manuals, Master-Bilt will provide them free. Contact the customer service department at Master-Bilt at (800) 684-8988.

The customer service department at Master-Bilt should be contacted at the time of sale or disposal of your cabinet so records may be kept of its new location.

If you sell or give away your Master-Bilt cabinet and you evacuate the refrigerant charge before shipment, Master-Bilt recommends that the refrigerant charge be properly recovered in compliance with section 608 of the Clean Air Act effective November 1995 and in accordance with all applicable local, regional, or national standards.

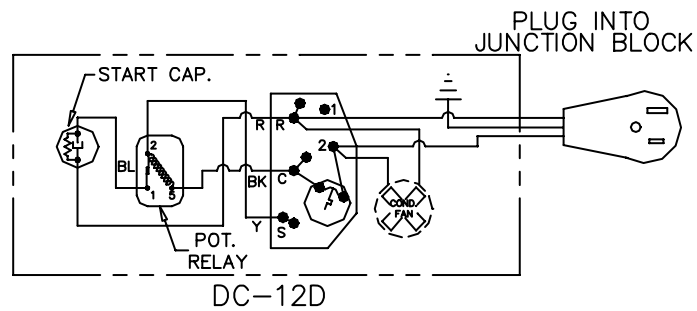
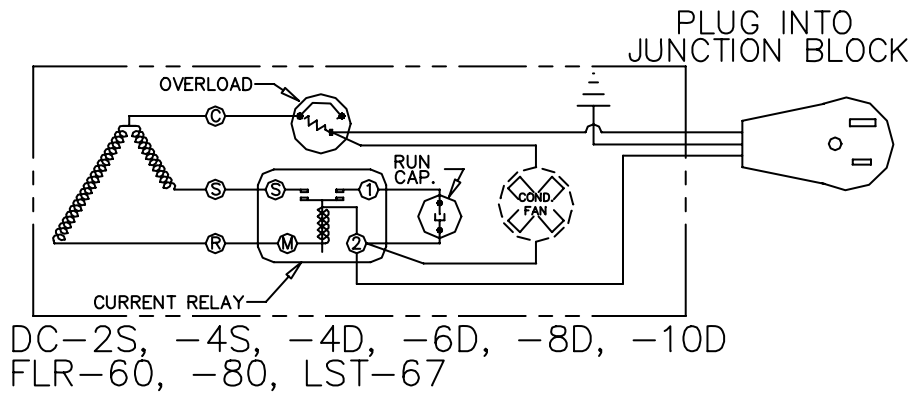
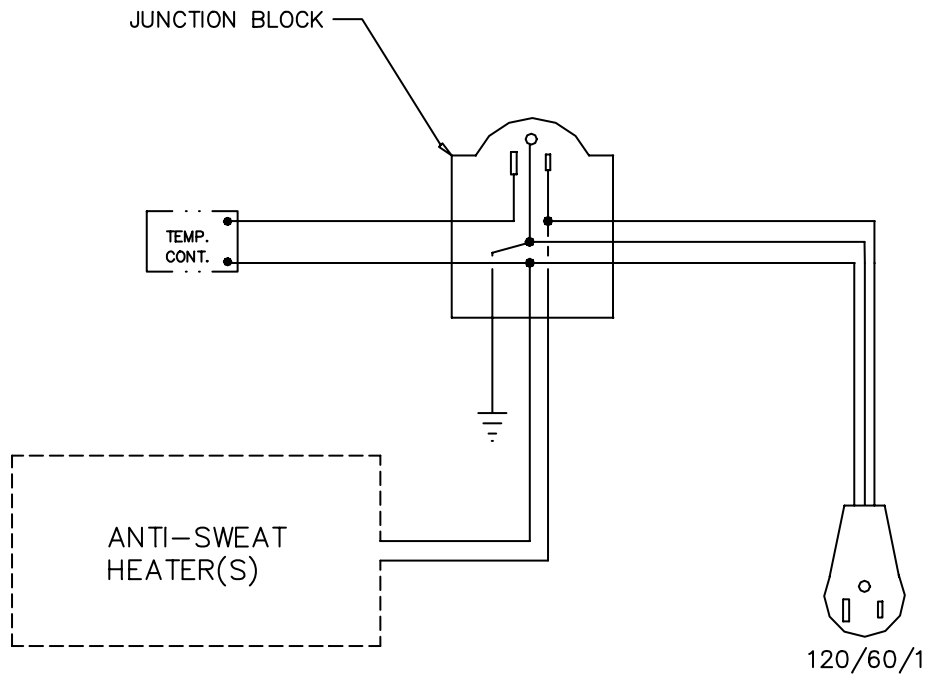

REV. 3/16/01
5/11/00

WIRING DIAGRAM DC-2S, -4S, -4D, -6D, -8D, -10D, -12D
FLR-60, -80, LST-67

DCFLRLST