

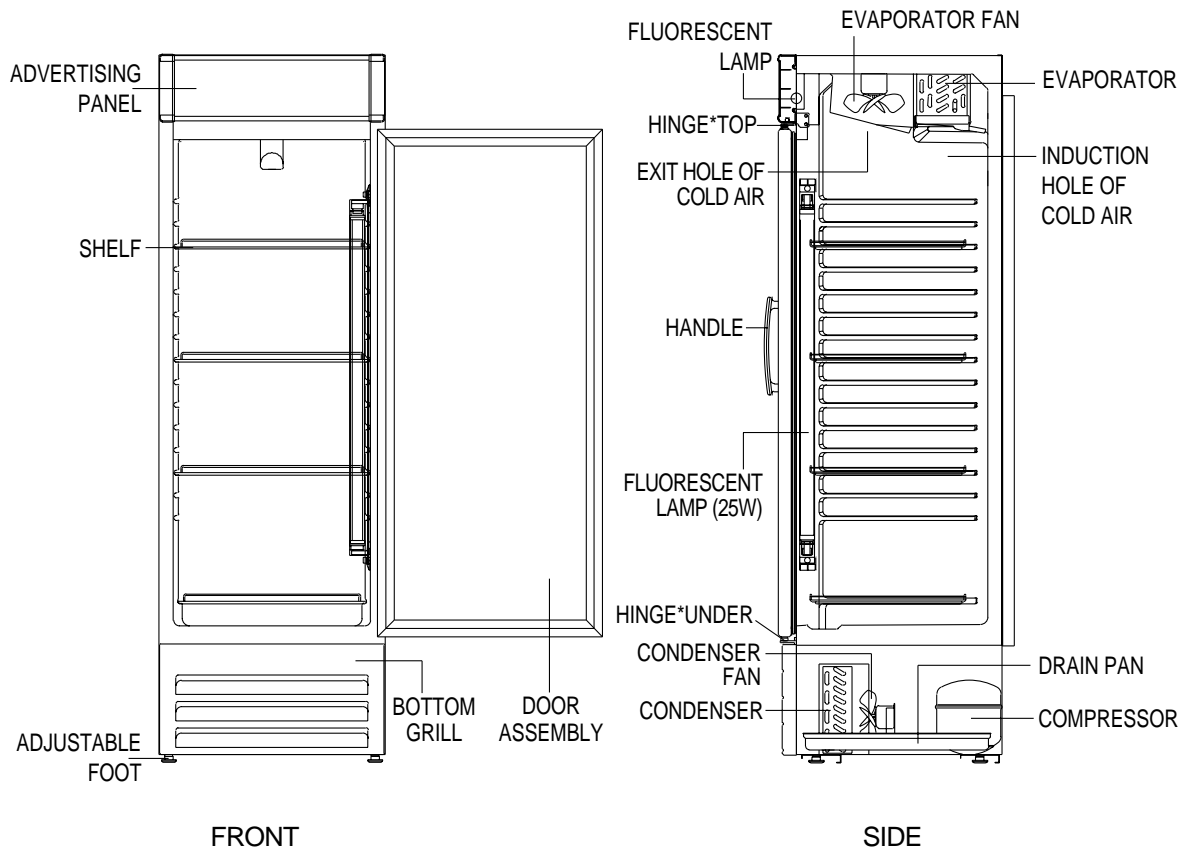

# GLASS DOOR MERCHANDISER INSTRUCTION MANUAL

Model No.: **BGR-14R**

## FEATURE CHART



Before operating this unit, please read these instructions completely.

## HOW TO INSTALL

### ■ In good ventilation.

- Place the refrigerator in a well ventilated area for better cooling.
- Temperature of room should be less than 90°F degrees.

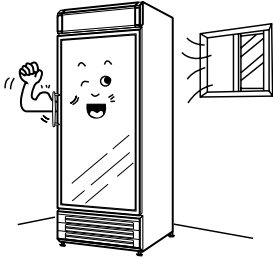

### ■ Place the refrigerator on hard and level floor.

- Unlevel floor may cause the refrigerator to make noise.

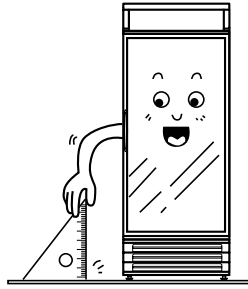

### ■ Put away heat source from the refrigerator.

- High ambient temperature will make cooling efficiency lower.

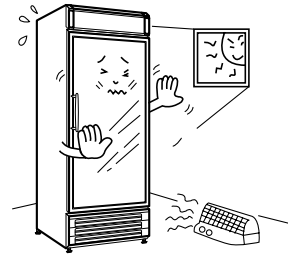

### ■ Install the refrigerator indoors only.

- The refrigerator should not get wet.



### ■ Avoid places that are exposed to smoke.

- Discoloring can occur to the refrigerator.

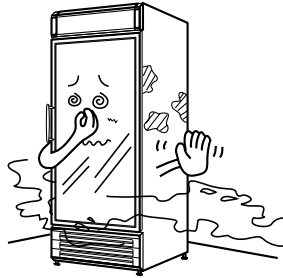

### ■ Place the refrigerator in an area with low moisture.

- Splashing water or a high moisture area may cause short circuit and make rusting easier.



### ■ Install the refrigerator on the places with 41~95°F.

- Do not set temperature control too cold. Food may freeze and soda containers may burst.

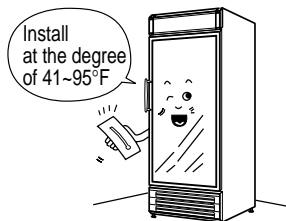

### ■ Set the front of the refrigerator a little bit higher than back-side by using adjustable feet to drain the water away with easily.

Set the front side higher than back side.

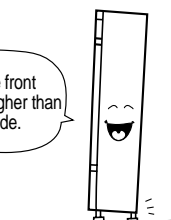

### ■ Adjust the temperature in the refrigerator.

- Temperature control is located on top right side. Set knob to normal position.

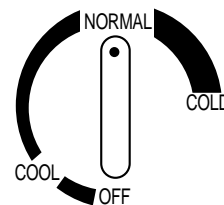

## CLEANING

### ■ Cleaning the interior and exterior

- Wash with warm soapy water and rinse with wet cloth.
- Wipe with dry cloth.
- Clean gasket frequently.
- Wash shelves with water.
- If unit has dew drops on exterior, wipe away with dry cloth. This tends to happen in the rainy season.

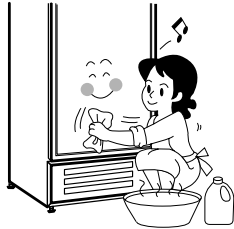

### ■ Check points after cleaning

- Check again the refrigerator for safety.
- Do not plug the power cord with wet hands.
- Check for noise or unit not getting cold.



### ■ Compressor

- A dirty condenser will not let unit cool efficiently. Clean the condenser every three months by using a brush or vacuum cleaner.
- Especially, be sure to clean the condenser before reoperating, after a long period of non-operation.

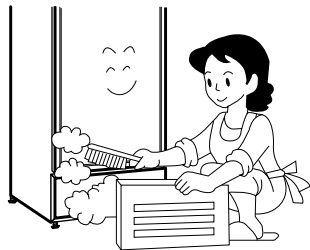

### ■ Caution

- Unplug the power cord before cleaning.
- Clean the refrigerator periodically.
- Do not use the abrasive cleaners, solvents or polishing agents on plastic parts. These cleansers may cause cracking or discoloring.



### ■ Drainage

- Take out the bottom grill to empty the tray.
- Clean it at least once in 2days.  
(in rainy season, it needs everyday.)



## CAUTION

### ■ Ventilation

- Place the unit in a well ventilated area.
- Keep the cabinet 4" from rear wall.

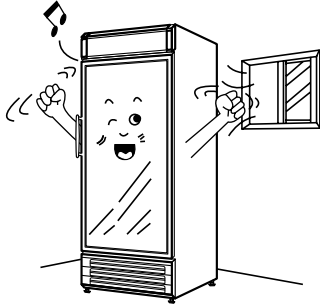

### ■ Warning

- Warranty will be voided if the following is found.
  - Low voltage to unit. Should be 115V/60Hz.
  - Power cord should not be more than 7 feet long from plug in connection to compressor.
  - Multiple units plugged into same circuit.
  - On extension cord.

### ■ Start-up

- Plug the power cord into the wall outlet.
- The outlet should be only for the refrigerator.
- The temperature controller should be on normal position.
- If disconnected, shut down, wait 5 minutes before re-starting it.

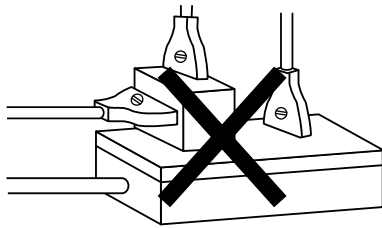

### ■ Temperature control

- To keep the temperature down : Turn the dial by CLOCK-WISE.
- To keep the temperature up : Turn the dial by COUNTER-CLOCK-WISE.

### ■ Power card replacement

- If the supply card is damaged, it must be replaced by the manufacturer or its service agent or a similarity qualified person in order to avoid a hazard.

### ■ Before you operate the unit.

Please unscrew the Bottom grill and take out the pad in the Drain pan.

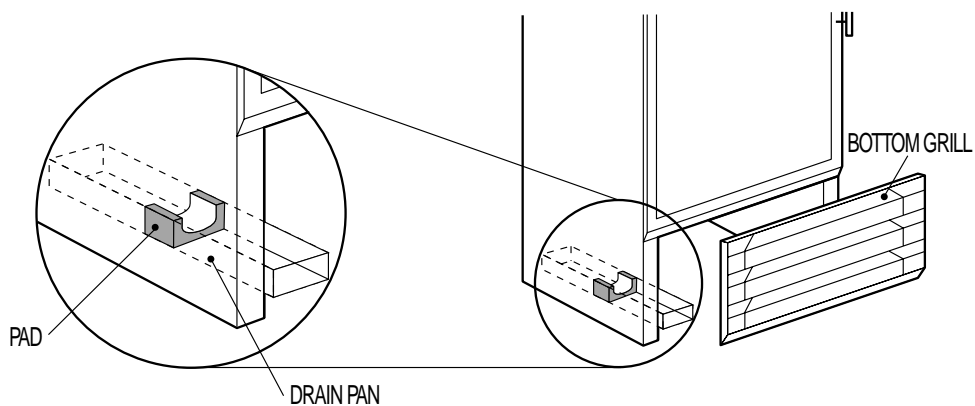

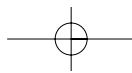

## BEFORE REQUESTING SERVICE



SYMPTOMS	CAUSES	SOLUTIONS
Product freezing	• Only a small amount of product stored in unit.	• Turn temperature control to normal.
	• Product on top shelf only freezing.	• Rearrange product, due to close to fan.
	• Temperature of refrigerator below 35°F.	• Turn temperature control to normal.
Not working - compressor and light not on	• Power or electrical failure.	• Check power by plugging power cord into another outlet that has power.
Refrigerator not cooling well.	• When the refrigerator is in sunlight or near a unit that disperses heat.	• Remove from heat source.
	• When the refrigerator contains hot food or too much food.	• Remove hot food and allow to cool.
	• When the temperature control is not set correctly.	• Check position of temperature control.
	• When condenser coil is dirty.	• Clean condenser.
	• When refrigerator door is opened frequently or left open.	• Check the refrigerator door.
Noisy	<ul style="list-style-type: none"> <li>• When the installation floor is weak or the adjustable feet is set incorrectly.</li> <li>• When the back-side of the refrigerator is close to the wall.</li> <li>• When the tray is not on the correct position.</li> </ul>	• Check the installation and insert the tray correctly.
Moisture on exterior of cabinet.	• High-moisture air can produce dewdrops during the rainy season.	• Wipe with dry cloth.
Moisture on interior of cabinet.	• When food with steam is stored.	• Wipe with dry cloth.
	• When door is opened frequently.	• Keep door closed as often as possible. Wipe with dry cloth.
Door does not close correctly.	• When door has slant.	• Adjust feet under cooler.
	• When floor is not level.	• Level unit.
	• When door gasket comes out of place.	• Reinsert gasket.

The following points are not malfunctions:

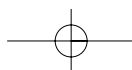
- Water-flowing sound can be heard when the compressor stops.  
This is a sound of REFRIGERANT flowing.
- When compressor stops by temperature control, it is not out of order.
- This is necessary so ice will not build up on evaporator.
- The door is warm to touch, due to heater that is installed.

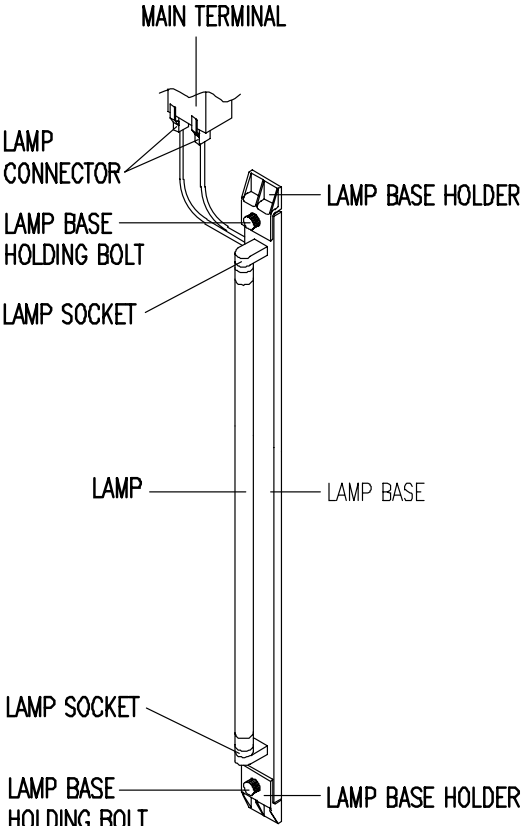

## HOW TO ADJUST A SHELF POSITION AND REPLACE A LAMP

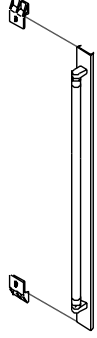
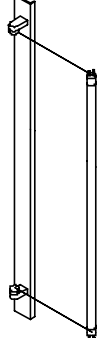
 <p>Please turn off the power before the positioning of shelves and installing a lamp.</p> <ul style="list-style-type: none"> <li>- Care for electric shock.</li> </ul>	 <p>Pull the lamp connector off the main terminal.</p> <ul style="list-style-type: none"> <li>- Don't hold the wire but the connector housing while pulling it off.</li> </ul>
	 <p>Unscrew the lamp base holding bolt (2EA) from the lamp base.</p>
	 <p>Detach the lamp base holder from the lamp base.</p> <p>★ After the work is done up to this stage The shelves can be adjusted into new position.</p>
	 <p>Separate the lamp from the lamp socket, and replace with the new lamp.</p>

WARRANTY

**MASTER-BILT.**

**LIMITED ONE YEAR WARRANTY**

Master-Bilt Products (the "Company") warrants to the original purchaser-user that its refrigeration equipment, at the time of delivery, will be free from defects in material and workmanship. Written notice of a claim under this Warranty must be received by the Company within ONE YEAR from date of installation but no longer than ONE YEAR AND THREE MONTHS from shipment.

Defective conditions caused by abnormal use or misuse, lack of or improper maintenance, damage by third parties, alterations, acts of God, failure to follow installation, maintenance or safety instructions or any other event beyond the control of the Company will not be covered under this Warranty.

The obligation of Master-Bilt shall be limited to repairing or replacing (at the option of the Company) any part which is defective in the reasonable opinion of the Company. The user will have the sole responsibility and bear all expenses related to removing and returning the defective part to the Company as well as the cost of reinstalling the replacement or repaired part.

THIS WARRANTY IS EXCLUSIVE AND IN LIEU OF ALL OTHER WARRANTIES, EXPRESS OR IMPLIED, INCLUDING THE IMPLIED WARRANTIES OF MERCHANTABILITY AND FITNESS FOR A PARTICULAR PURPOSE.

In no event shall the Company be liable for loss of use, revenue or profit or for any other indirect, incidental, special or consequential damages including, but not limited to, food spoilage or product loss.

This Warranty shall apply only within the continental United States, its territories and possessions and in Canada.

**LIMITED FIVE YEAR COMPRESSOR REPLACEMENT WARRANTY**

The Company warrants, to the original purchaser-user that it will replace the compressor on the Equipment if found, in the reasonable opinion of the Company, to be defective in material or workmanship if written notice is received within five years from date of shipment.

Defective conditions caused by abnormal use or misuse, lack of or improper maintenance, damage by third parties, alterations, acts of God, failure to follow installation, maintenance or safety instructions or any other event beyond the control of the Company will not be covered under this Warranty.

The Compressor Replacement Warranty does not apply to any part of the equipment other than the compressor. The user will have the sole responsibility and bear all expenses of removing and returning the defective compressor to the Company as well as the cost of reinstalling the replacement compressor. The Company may satisfy its obligations hereunder by supplying a replacement compressor which is reasonably similar in design and capacity.

THIS WARRANTY IS EXCLUSIVE IN LIEU OF ALL OTHER WARRANTIES, EXPRESS OR IMPLIED, INCLUDING THE IMPLIED WARRANTIES OF MERCHANTABILITY AND FITNESS FOR PARTICULAR PURPOSE.

In no event shall the Company be liable for loss of use, revenue or profit or for any other indirect, incidental, special or consequential damages, but not limited to losses involving food spoilage or product loss.

This Compressor Replacement Warranty shall apply only within the continental United States, its territories and possessions and in Canada.

Shipment Date: \_\_\_\_\_ Serial Number: \_\_\_\_\_

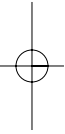
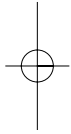
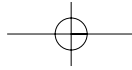

**MBMASTER-BILT<sup>®</sup>**  
*Refrigeration Solutions*

908 Highway 15 North • New Albany, MS 38652  
800-647-1284 • FAX: 800-232-3966  
SERVICE: 800-684-8988 • SERVICE FAX: 866-882-7629  
[www.master-bilt.com](http://www.master-bilt.com)

