

MB MASTER-BILT[®]

Refrigeration Solutions

GEL SERIES ALL-AMERICAN GELATO & ICE CREAM MERCHANDISER



**Made In The USA
& Meets These Listings**



ANSI/NSF 7

MB MASTER-BILT®

GEL SERIES

FEATURES & BENEFITS

- Manufactured in the USA for faster service and parts and no dollar fluctuation
- Three models available: GEL-6 (6 pans wide), GEL-9 and GEL-12
- Concealed evaporator coils protect from spills
- GEL merchandisers ship assembled – some competitor models don't
- Adjustable temperature range of -5°F to 20°F makes GEL models ideal for displaying gelato, ice cream, sorbet or Italian ice
- Two levels of pans allows one level for display and one underneath for storage
- Sliding rear lids on back
- Standard electronic controller
- Standard power cord
- Hot gas defrost
- Rear air intake and front air discharge
- Standard T8 electronic lighting with LED optional
- GEL-6 refrigeration system contains one condensing unit while the GEL-9 and GEL-12 contain two
- Semi-hermetic compressor(s) standard
- 2" thick walls with polyurethane insulation in the refrigeration compartment for dependable performance
- Standard black finish with stainless steel front panel; optional color finishes and laminates available
- Optional casters, pans and dipperwells



Glass lid is top hinged for easy cleaning. Pneumatically supported lid provides smooth closure.



GEL models can be configured to hold five liter European pans or USA standard 1/3 size. Pans are optional on all GEL models.

DIMENSIONS

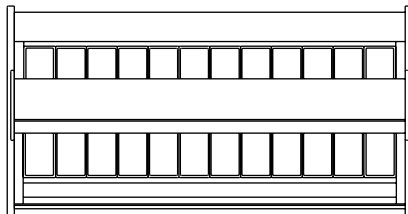

PLAN VIEW

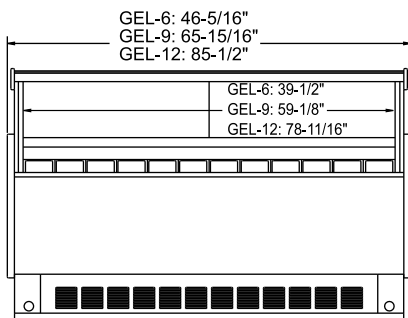

ELEVATION VIEW

GEL-6: 46-5/16"
GEL-9: 65-15/16"
GEL-12: 85-1/2"

GEL-6: 39-1/2"
GEL-9: 59-1/8"
GEL-12: 78-11/16"

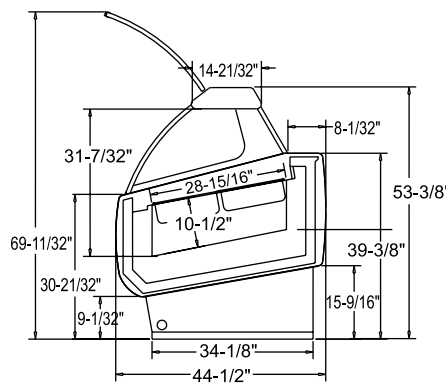

SIDE VIEW



908 Highway 15 North • New Albany, MS 38652
800-647-1284 • FAX: 800-232-3966
www.master-bilt.com



Due to continuous product enhancements, all specifications subject to change without notice.
1263-11/10-web ©Master-Bilt division of Standex International, Inc. All rights reserved. Printed in USA.